

# Sources and Environmental Cycling of POPs in the Baltic Sea Region:

*Case studies for  $\alpha$ -HCH and  $\gamma$ -HCH using the  
POPCYCLING-Baltic model*

**Knut Breivik, Frank Wania, Jozef M. Pacyna**





**Norwegian Institute for Air Research**  
PO Box 100, NO-2027 Kjeller, Norway  
**Chemical Co-ordinating Centre of EMEP (CCC)**

NILU : EMEP/CCC-Report 4/2001  
REFERENCE : O-100120  
DATE : MAY 2001

**EMEP Co-operative Programme for Monitoring and Evaluation  
of the Long-range Transmission of Air Pollutants in Europe**

# **Sources and Environmental Cycling of POPs in the Baltic Sea Region:**

*Case studies for  $\alpha$ -HCH and  $\gamma$ -HCH using the  
POPCYCLING-Baltic model*

**Knut Breivik<sup>1</sup>, Frank Wania<sup>2</sup>, Jozef M. Pacyna<sup>1</sup>**

<sup>1</sup> Norwegian Institute for Air Research, NILU

<sup>2</sup> University of Toronto at Scarborough, U of T



Norwegian Institute for Air Research  
P.O. Box 100  
N-2027 Kjeller, Norway  
Tel.: +47 6389 8000 – Fax: +47 6389 8050



# Contents

	Page
<b>Summary .....</b>	<b>3</b>
<b>1. Introduction.....</b>	<b>5</b>
<b>2. Use of <math>\alpha</math>-HCH and <math>\gamma</math>-HCH in Europe, 1970-1996.....</b>	<b>6</b>
<b>3. Brief description of the Baltic Sea and the POPCYCLING-Baltic model.....</b>	<b>9</b>
3.1 The Baltic Sea and its drainage area .....	9
3.2 Brief description of the POPCYCLING-Baltic model.....	10
<b>4. Parameterisation of the POPCYCLING-Baltic model .....</b>	<b>10</b>
4.1 Environmental input parameters .....	10
4.2 Chemical input parameters.....	12
4.3 Emission input data .....	13
4.4 Boundary conditions .....	14
<b>5. Evaluation of model results.....</b>	<b>15</b>
5.1 Spatial concentration patterns .....	15
5.1.1 Seawater .....	15
5.1.2 Sediments .....	16
5.1.3 Needles .....	18
5.2 Concentration time trends .....	19
5.2.1 Atmosphere .....	19
5.2.2 Sea Water .....	20
5.2.3 Comparison with time-trends in fish.....	24
<b>6. Application of the model for pathway and flux analysis.....</b>	<b>25</b>
6.1 Sources of HCH within and outside of the Baltic Sea drainage basin .....	27
6.2 Pathways within the marine environment of the Baltic sea .....	29
6.3 Temporal trends in emissions and accumulated amounts.....	32
6.4 Reservoirs within the drainage basin of the Baltic Sea.....	34
6.5 Pathways within the drainage basin of the Baltic Sea .....	34
6.6 Atmosphere-surface equilibrium status and flux direction .....	39
6.7 Water-sediment equilibrium status and flux direction .....	41
6.8 Uniformity versus variability within the Baltic Sea environment .....	48
<b>7. Discussion and recommendations .....</b>	<b>49</b>
7.1 Discussion governing the specific model analysis presented .....	49
7.2 Prospects for modelling other chemicals using the POPCYCLING-Baltic model.....	50
7.3 Application of the POPCYCLING-Baltic model in the EMEP program .....	51
<b>8. Acknowledgements .....</b>	<b>52</b>
<b>9. References.....</b>	<b>52</b>
<b>10. Abbreviations .....</b>	<b>57</b>



## Summary

Substantial research efforts are undertaken internationally on issues related to the sources, environmental behaviour and fate of POPs (Persistent Organic Pollutants) through various research projects, and as integral activities under various international conventions and programmes, such as EMEP. This report presents selected results from a completed EU-project on regional cycling of POPs in the Baltic Sea Environment (Pacyna et al. 1999). In this report we focus on the regional fate of  $\alpha$ -HCH and  $\gamma$ -HCH, using the POPCYCLING-Baltic model (Wania et al. 2000).

Earlier model approaches covering the Baltic Sea drainage basin have focused on the atmospheric transport and deposition of HCHs in Europe (Persson and Ullerstig, 1996; Van Jaarsveld et al. 1997) and the Baltic Sea (Bartnicki et al. 1998). Recently, increasing efforts have been undertaken at the EMEP Meteorological Synthesizing Centre – East, to study the regional cycling of POPs including the HCHs over the EMEP model domain by the use of models (e.g. Shatalov et al. 2000; Shatalov and Malanichev, 2000).

In this report, the POPCYCLING-Baltic model (Wania et al. 2000) is shown to successfully reproduce many aspects of the long-term fate of HCHs in the Baltic Sea environment. Concentrations in air, seawater, marine sediments and needles are predicted well within an order of magnitude, in most cases within a factor of two. The model reproduces the relatively uniform concentrations of HCHs observed in seawater across the Baltic Sea region. The model also captures the time trends of  $\alpha$ -HCH observed in air, seawater, fresh water fish and marine fish. The spatial and temporal patterns of HCHs in the Baltic Sea environment are found to be controlled mostly by chemical input, both through direct emissions within the drainage basin and through advective inflow from adjacent areas, but variable environmental conditions can significantly modify the spatial distribution patterns. Simulations with different boundary conditions, i.e. variable assumptions concerning advective atmospheric inflow, suggest that sources within the drainage basin alone are not capable to explain the observed HCH levels and significant transport into the region must occur. Deviations between predicted and measured HCH concentrations can often be explained by uncertain estimates of usage and advective import, illustrating the usefulness of the model for evaluating the reasonability of emission estimates and boundary conditions.

Through application of the model for flux and pathway analysis, it is shown that the atmosphere is found to effectively distribute the HCHs within the Baltic Sea environment and beyond, resulting in relatively uniform concentrations in environmental compartments that do not directly receive emissions. This uniformity is the result of a large-scale re-distribution of a relatively small fraction of the emitted HCHs from the agricultural systems in source areas to all other environmental compartments throughout the Baltic Sea region. The major fraction of the HCHs is degraded in the soils receiving the pesticide application. In areas where HCH-containing pesticides are used, HCHs evaporate from soils and water bodies, and are advected away in the atmosphere. They are deposited to forests and water bodies when they reach remote regions. This redistribution is

driven by the inclination of the HCHs to equalise their chemical potential within the environment, which is illustrated through the use of fugacity fractions.

The POPCYCLING-Baltic model is believed to provide invaluable insight into the complex set of interactions that determine the overall fate of an environmental contaminant, but which are inaccessible to measurements. Further use of the POPCYCLING-Baltic model for other POPs are encouraged and a full sensitivity analysis should be undertaken to increase confidence in the predictive capability of the model.



# Sources and Environmental Cycling of POPs in the Baltic Sea Region:

## A case study for $\alpha$ -HCH and $\gamma$ -HCH using the POPCYCLING-Baltic model

### 1. Introduction

This purpose of this report is to present selected results from the EU POPCYCLING-Baltic project (Pacyna et al. 1999) and to highlight some of the outcome and methodologies considered of particular relevance for EMEP in relation to the ongoing work on Persistent Organic Pollutants (POPs).

The overall scope of the POPCYCLING-Baltic project was to develop a comprehensive multi-compartmental model to study the long-time fate and behaviour of POPs in the Baltic Sea environment.

The following POPs were selected in the project:

- (1) Hexachlorocyclohexanes,
- (2) Selected Polychlorinated Biphenyls,
- (3) Hexachlorobenzene,
- (4) Dichloro-diphenyl-trichloroethane (DDT) and its metabolites,
- (5) Benzo[a]Pyrene, and
- (6) Selected dibenzodioxins and dibenzofuranes

Specific objectives of the project were:

- (a) Model development.
- (b) Elaboration of an emission database for POPs in Europe.
- (c) Elaboration of an environmental database with measured concentration data for POPs in the model region for model evaluation purposes.
- (d) Preparation of a set of recommendations with respect to the exposure and risk assessment of POPs in the Baltic Sea region.

The overall outcome and results of the POPCYCLING-Baltic project are summarised in Pacyna et al. (1999). In this report, only a brief description of the Baltic Sea drainage basin is given, along with a short description of the POPCYCLING-Baltic model (Wania et al. 2000). Furthermore, we present selected results of the accompanying European usage and emission inventory for  $\alpha$ -HCH and  $\gamma$ -HCH (Breivik et al. 1999; Pacyna et al. 1999). Emphasis in this report is however on model evaluation (*which in one way or other involve the comparison of the model predictions with the observed behaviour of HCHs*) and model application (*whereby the model is used for flux and pathway analysis*) for these two insecticide isomers. Finally, a set of conclusions and recommendations are presented along with a discussion on the feasibility for further studies and its relevance for EMEP and other conventions and programmes.

## 2. Use of $\alpha$ -HCH and $\gamma$ -HCH in Europe, 1970-1996

Hexachlorocyclohexane (HCH) is one of the most intensively studied pesticides with respect to its sources, environmental distribution, fate and effects (e.g. Willett et al. 1998; Li, 1999). HCH in the environment principally occurs as a result of the consumption of insecticides. HCH thus belongs to the insecticide group of pesticides that has been extensively used world wide since the 1940s (Li et al. 1998), and are recognised to be enriched towards the Arctic, thus having higher concentrations in the northern environment than in major source regions at mid-latitudes (Wania and Mackay, 1996).

The HCHs are manufactured by chlorination of benzene, and five (*out of eight*) isomers are stable ( $\alpha$ -,  $\beta$ -,  $\gamma$ -,  $\delta$ - and  $\epsilon$ -HCH). In this report, we address two of the quantitatively most important isomers, namely  $\alpha$ -HCH and  $\gamma$ -HCH. The chemical structures of  $\gamma$ -HCH and  $\alpha$ -HCH are given in Figure 1.  $\alpha$ -HCH is the dominant isomer of an unpurified technical mixture of various isomers, where the content of the  $\alpha$ -isomer lies between 55 and 80% (Breivik et al. 1999).  $\gamma$ -HCH, on the other hand, is a minor constituent within technical HCH (8-15%  $\gamma$ -HCH), but the principal constituent of lindane (almost 100%  $\gamma$ -HCH).  $\gamma$ -HCH is also the isomer that has the most significant insecticidal activity (Kutz et al. 1991).

Figure 1: Chemical structure of  $\gamma$ -HCH and  $\alpha$ -HCH.

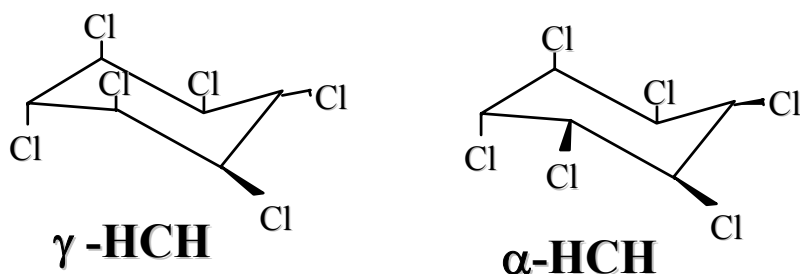

Details about the inventory for HCHs may be found in Breivik et al. (1999). Here, only the key findings are presented. The usage was based on reported values or estimated for each European country and year from 1970 to 1996 based on:

- (1) National reported data (Norway, Denmark, U.K.).
- (2) Reported data on lindane, technical HCH or  $\Sigma$ HCH usage from various institutions, programs, reports and articles.
- (3) Statistical data on insecticide consumption from FAO, EUROSTAT and UNEP.
- (4) Information on national and regional measures against usage of lindane and technical HCH.

Figure 2: Estimated historical consumption of  $\alpha$ -HCH (259 000 tonnes) and  $\gamma$ -HCH (135 000 tonnes) in Europe, 1970-1996.

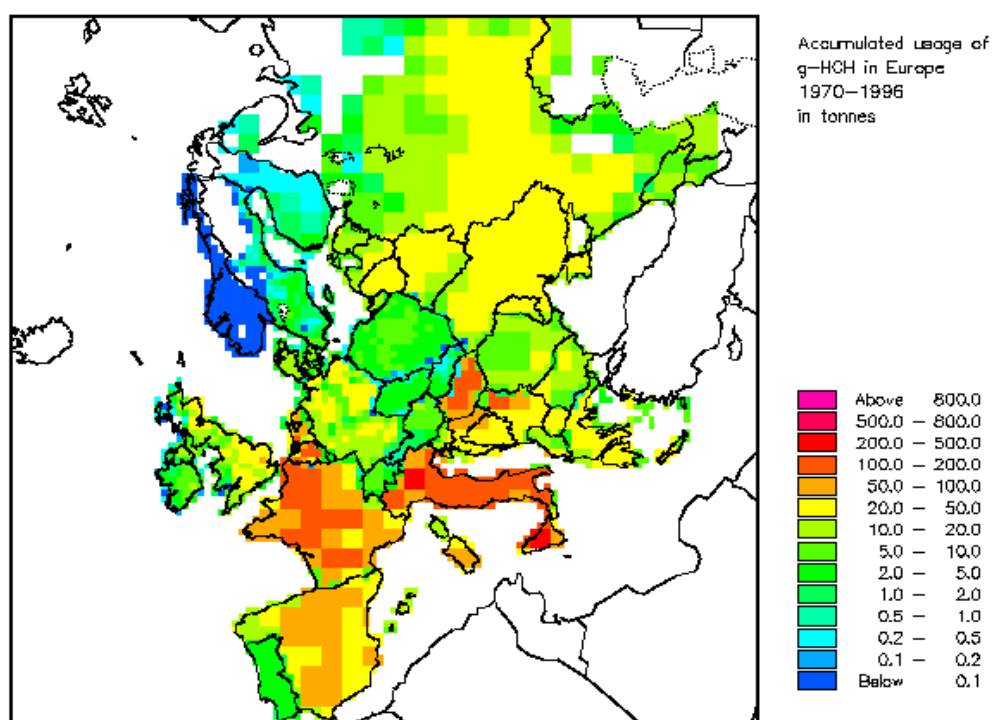
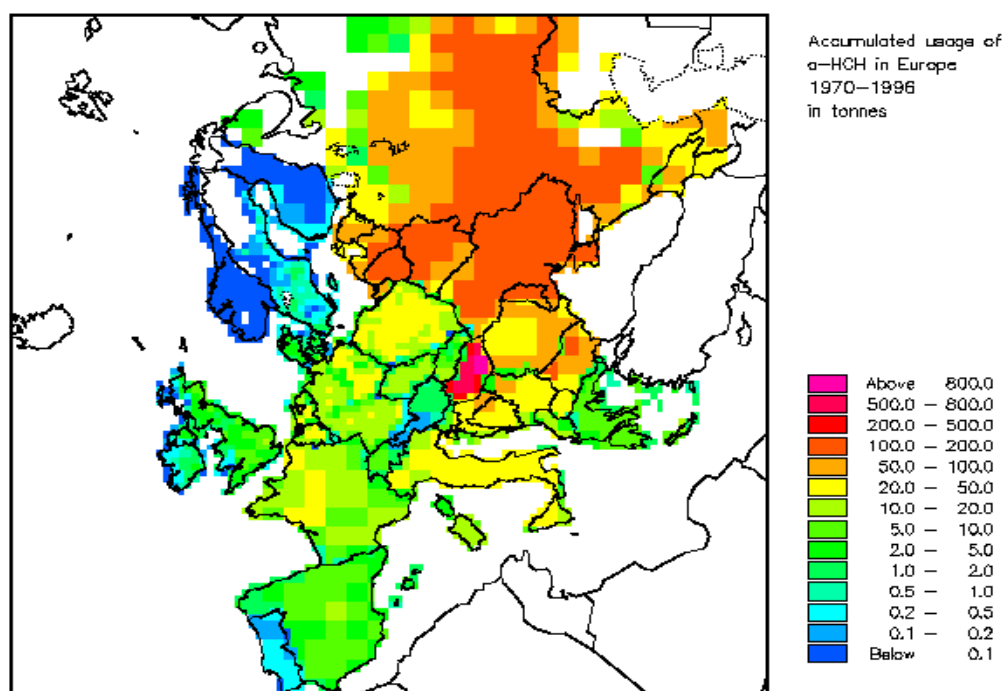

The spatial distribution of the estimated historical consumption of these two isomers in Europe from 1970 to 1996 is presented in Figure 2, using crop area as a surrogate parameter to distribute the national consumption data. The study by Breivik et al. (1999) further suggests that 382 000 tonnes of technical HCH and 81 000 tonnes of lindane were used in Europe from 1970 to 1996, which again is equivalent to an estimated cumulative consumption of 259 000 tonnes  $\alpha$ -HCH and 135 000 tonnes  $\gamma$ -HCH. For comparison, the total global technical HCH usage between 1948 and 1997 has been estimated to be approximately 10 million tonnes (Li, 1999). The data from Breivik et al. (1999) also indicates that technical HCH was predominantly used in the former Eastern European countries, here represented by  $\alpha$ -HCH. In the mid-90s France was presumably the principal user of  $\gamma$ -HCH, using about 60 percent of the European total. However, in May 1998 France banned lindane usage (CIEL, 1998), so in the last years total European usage has presumably been only a few hundred tons annually.

It is however important to recognise the most significant uncertainties inherent in these estimated consumption data, the most important ones being (Breivik et al. 1999):

- (1) Uncertainties regarding whether usage are reported for active ingredient or plus diluting agents, and
- (2) the distinction between technical HCH and lindane usage when no information on the subject is given (*when available data are referred to as total HCH or BHC usage*), as well as
- (3) the use of ratios describing HCH to total insecticide usage to estimate HCH consumption (*in countries where only information on insecticide usage were available*).

In general, the accuracy of the data is increasing from the 1970s to the 1990s, thus reflecting the availability of reliable data. In spite of these uncertainties, we anticipate that important aspects of the temporal and spatial pattern of European consumption are captured in this inventory, although the uncertainties may be significant at a more detailed level, e.g. for individual countries and years. The temporal trend in European consumption of  $\alpha$ -HCH and  $\gamma$ -HCH as well as the other isomers are presented in Figure 3. Here it is clearly seen that the estimated usage of  $\alpha$ -HCH has decreased much more than the  $\gamma$ -HCH during the time-period. As of 1996, the European usage of  $\gamma$ -HCH was still estimated to be nearly one-third as compared to 1970. The availability of information indicates that the recent data are the more accurate than the data from the past.

Figure 3: Annual consumption of  $\gamma$ -HCH,  $\alpha$ -HCH and other HCH isomers ( $\beta, \delta, \epsilon$ ) in Europe in tonnes per year (Breivik et al. 1999). The uncertainty is related to the overall HCH estimate.

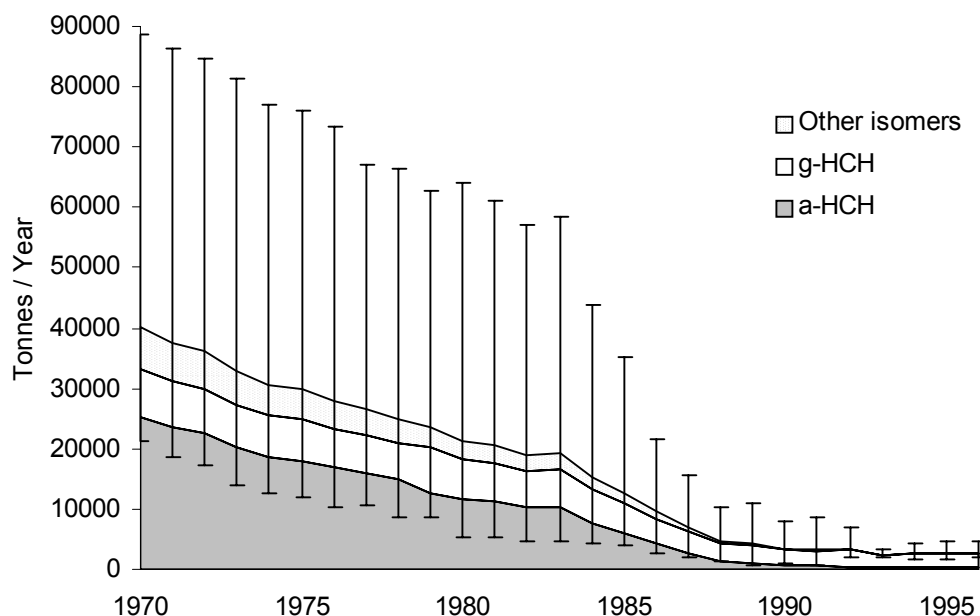

### 3. Brief description of the Baltic Sea and the POPCYCLING-Baltic model

#### 3.1 The Baltic Sea and its drainage area

The Baltic Sea is a shallow, semi-enclosed sea that could almost be viewed as a separate hydrological unit. The two main features of the water balance of its interconnected regions and bays have been described by the inflow of freshwater from river basins in the drainage area, and of saline water from the North Sea (UN, 1987). This region includes parts of fourteen countries (*Belarus, Czech Republic, Denmark, Estonia, Finland, Germany, Latvia, Lithuania, Norway, Poland, Russia, Slovak Republic, Sweden and Ukraine*). The Baltic Sea is claimed to be the most thoroughly studied sea area in the world. For a recent review of the environmental status of the Baltic Sea, see Jansson and Dahlberg (1999).

The widespread occurrence of POPs has been a major environmental concern in the area for decades (e.g. Jensen et al. 1969; Bignert et al. 1998). The availability of data on environmental characteristics as well as measured concentrations of POPs in this region greatly facilitated and justified the development, parameterisation, evaluation and application of the POPCYCLING-Baltic model.

### 3.2 Brief description of the POPCYCLING-Baltic model

A full description of an optimised version of the POPCYCLING-Baltic model was recently given by Wania et al. (2000). This version of the model has been applied here. The POPCYCLING-Baltic model may be characterised as a Multimedia Fate and Transport Model (MFTM) based on the fugacity approach (Mackay, 1979; Mackay, 1991). Fugacity based MFTMs are designed to give a qualitative and quantitative understanding of the environmental transport and fate of chemicals which have partitioning properties which results in a propensity to be present within two or more environmental compartments (*so-called multimedia pollutants*) – see e.g. Wania and Mackay (1999a). An outline of various approaches that are used to model the environmental distribution of POPs, i.e. by use of MFTMs versus the more classical air pollution dispersion models can be found in Wania (1999a).

Briefly, the POPCYCLING-Baltic model consists of 85 well-mixed boxes (*assumed to have homogenous environmental characteristics and chemical concentrations*) which represent a variety of environmental phases and which are linked by a variety of inter-compartment transfer processes. The marine environment of the Baltic Sea is represented by 16 water and 15 sediment compartments, whereas the terrestrial environment is divided into 10 drainage basins, each being described with 5 compartments (*agricultural soil, forest soil, forest canopy, fresh water, fresh water sediment*). The atmosphere over the drainage basin is divided into four atmospheric units. The compartmentalisation of the Baltic Sea drainage basin is shown in Figure 4.

## 4. Parameterisation of the POPCYCLING-Baltic model

### 4.1 Environmental input parameters

The POPCYCLING-Baltic model is site-specific and thus requires environmental input parameters that describe the properties and environmental characteristics of the Baltic drainage basin (see Wania et al. 2000 for details). As the transport of lipophilic contaminants is highly influenced by the movement of air, water and particulate organic carbon (POC), complete mass balances synthesising the fluxes of these three environmental media have been constructed for the entire basin. The contaminant mass balance equations for the 85 compartments are superimposed on these mass balances for air, water and POC. Of particular importance for the relatively volatile and water soluble HCHs, are the water balance and the atmospheric advection rates. Long term average monthly mean fluxes for the exchange of air masses between the four air compartments and between the compartments and the atmosphere outside the model region were derived using a three-dimensional air dispersion model (*Dr. Jesper Christensen, Department of Atmospheric Environment, National Environmental Research Institute, Roskilde, Denmark*). These advection rates show:

- (1) a net eastbound flux of air masses,
- (2) a limited net air mass exchange in the north-south direction,
- (3) that the estimated residence time of air in the atmospheric compartments is approximately one day during summer and half a day during winter.

Figure 4: Maps showing the horizontal compartmentalisation of the terrestrial (A), marine (B) and atmospheric (C) environment of the Baltic Sea drainage basin in the POPCYCLING-model.

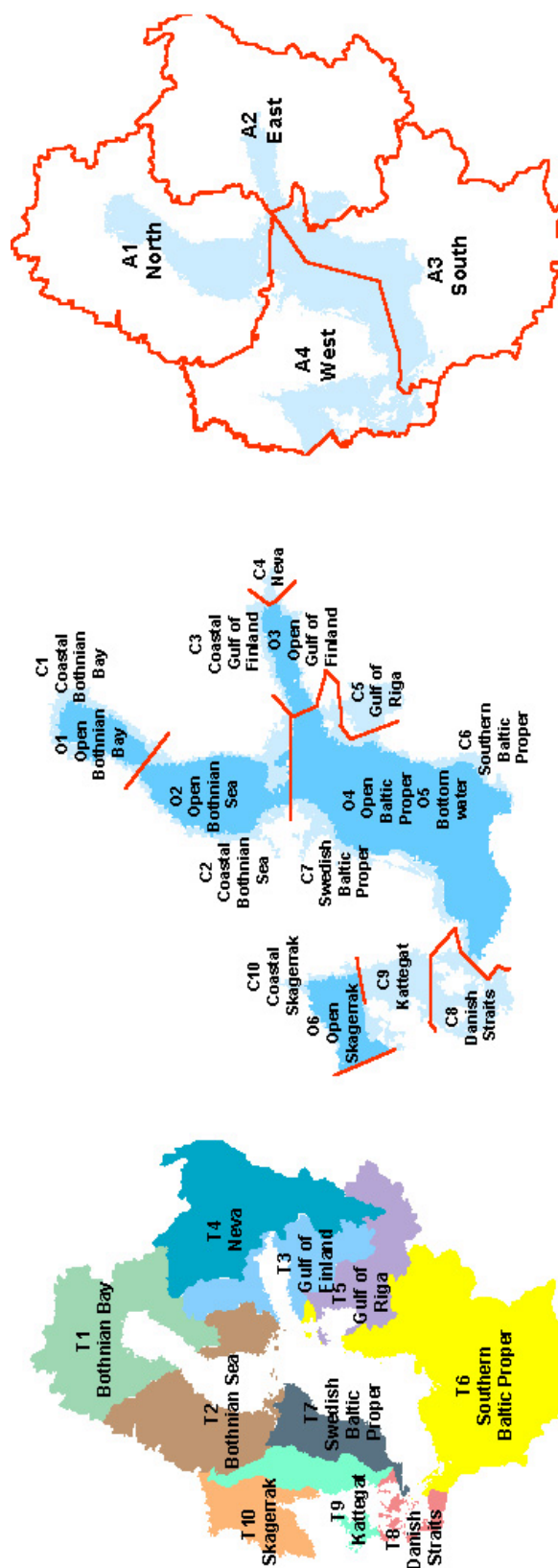

Daily temperatures for the four atmospheric regions were derived from data supplied by the Norwegian Meteorological Institute (DNMI).

The water mass balance for the drainage basin is building upon a variety of sources to derive consistent fluxes. The water balance study by HELCOM (1986) has been the most important single source of information. Water fluxes are assumed static in the model, neglecting seasonality of precipitation and evaporation. The POC mass balance, which is dependent on the water mass balance, is constructed based on an in-depth literature review of organic carbon dynamics in the model region (see Wania et al. 2000).

## 4.2 Chemical input parameters

The model aims to describe how climatic parameters, in particular temperature, influence the behaviour and persistence of POPs in the environment. To meet this objective, physical-chemical properties that determine environmental phase partitioning and degradation rates are described by functions of seasonable and spatially variable temperatures. The model uses three partition coefficients to describe environmental phase partitioning (octanol-water;  $K_{ow}$ , air-water;  $K_{aw}$  and octanol-air;  $K_{oa}$ ). Only two have to be provided as input, the third being calculated from the others. The temperature dependence of these coefficients is expressed using heats of phase transfer ( $\Delta U_{ow}$ ,  $\Delta U_{aw}$ ,  $\Delta U_{oa}$ ). The selected values for  $\alpha$ - and  $\gamma$ -HCH are given in Table 1. Atmospheric degradation of HCHs in the atmosphere is assumed to occur by reaction of the chemical in the gas phase with hydroxyl radicals and is described as in the global distribution model (Wania et al. 1999) requiring the input of a reaction rate at a reference temperature and an activation energy (Table 1).

Seasonally variable hydroxyl concentrations for the four air regions were derived from information in Rodriguez et al. (1992). The longest atmospheric half-lives are obtained during winter. For  $\alpha$ -HCH a maximum half-life in the atmosphere of 893 days in the Northern region and 618 days in the southern region are calculated, while a minimum is derived during summer with 135 days in the Northern region and 84 days in the southern region. Similar maximum and minimum values for  $\gamma$ -HCH are during winter 658 and 455 days, and during summer 99 and 62 days for the Northern and Southern region, respectively.

The model further requires half-lives and the corresponding activation energies for the degradation reaction in all other types of compartment (Table 1). The estimated half-lives show a significant seasonal variation, but not as pronounced as those derived for the atmospheric compartments. Generally, the half-lives for HCHs in summer are shorter by a factor of two to three than in winter. The only notable exception is the sediments at the bottom of the Baltic Proper for which the temperature is assumed constant throughout the year.



Table 1: Physical chemical properties of  $\alpha$ -HCH and  $\gamma$ -HCH used in the model calculations.

<i>Formula weight, partition coefficients, enthalpies of phase transfer and reaction rate with OH-radicals</i>										
	Molecular mass (g/mol)	Log $K_{OW}$ [1]	Log $K_{AW}$	Log $K_{OA}$	$\Delta U_W$	$\Delta U_W$	$\Delta U_A$	Reaction rate with OH-radicals (cm <sup>3</sup> molecules <sup>-1</sup> sec <sup>-1</sup> ) [2]		
$\alpha$ -HCH	290.85	3.81	-3.58	7.39	-15000	63100	-78100	1.4*10 <sup>-13</sup>		
$\gamma$ -HCH	290.85	3.8	-3.96	7.76	-15000	57500	-72500	1.9*10 <sup>-13</sup>		
<i>Half-lives (hours) and activation energies (J/mol) in various compartments, common for both isomers</i>										
	Air	Forest canopy	Soil		Water			Sediment		
			Forest	Agri-cultural	Fresh	Coastal	Open	Fresh	Coastal	Open
Half-life (25°C)		2190	2190	2190	8760	8760	8760	17520	17520	17520
Activation energy	10000	30000	30000	30000	30000	30000	30000	30000	30000	30000

[1] Mackay et al. (1999), [2] Brubaker and Hites (1988)

### 4.3 Emission input data

The national HCH usage data from Breivik et al. (1999) were allocated to the ten terrestrial sub-units of the model for the individual years from 1970 to 1996 using crop area as a surrogate parameter. In addition to quantify the historical consumption, there is a need to specify the mode of release into the environment, in other words the fractions emitted into the various model compartments. This environmental release distribution is dependent on:

- (1) the type of application (*e.g. soil treatment, seed treatment*),
- (2) the physical state of the application formulation (*aqueous spray, solid etc.*),
- (3) the weather conditions at the time of application (*humidity, temperature, wind speed*), and
- (4) the sorptive capacity of the receiving media (*plants, soil*).

HCHs applied as a liquid in the field may at the moment of application either stick to a plant, the soil or stay in the air (*spray droplet drift-off*). Several studies have addressed different aspects of postapplication fate (*e.g. Cliath and Spencer, 1972; Haque and Schupman, 1989; Samuel and Pillai, 1990; Boehncke et al. 1990; Waliszewski, 1993; Bintein and Devillers, 1996; Waymann and Rüdél, 1995; Rüdél, 1997*). Our approach relies on a judgement of the relative importance of various factors controlling this mode of release, based on a review of the literature. According to UNEP (1995), about 59% of the total amount of lindane is used for soil treatment, while seed treatment accounts for 34%. Further, lindane is generally applied in liquid formulations (*mostly wettable powders*), and only a minor fraction in the solid state (*dusts, powders and granules*).

Based on the literature we assumed a mode of release of 17.5% to the atmosphere, 80% to the agricultural soil and 2.5% to fresh water. To capture the seasonality of

insecticide usage, we furthermore assumed a sinusoidal variability with maximum emission in June in all ten terrestrial regions. The usage and emissions are furthermore assumed constant at 1996 levels until the year 2000. To avoid starting with an unrealistically “clean” environment, a spin-up of ten years were applied (*assuming 1970 emission rates*).

#### 4.4 Boundary conditions

The drainage basin of the Baltic Sea is surrounded by regions to the West, South and East, which have seen substantial use of HCH containing pesticides (*see section 2*). Accordingly, the import of HCHs across the model boundaries may be as important in controlling levels in the drainage basin as are emission within the model domain. Individual boundary conditions need to be specified for the four atmospheric compartments as well as for the aquatic Skagerrak compartment, which borders onto the North Sea (see Figure 4). This is done by assuming that concentrations flowing into the drainage basin from a particular direction are a fraction or multiple of the concentration coming out of the drainage basin. A ratio greater than one implies a net inflow while a ratio smaller than one represents a net outflow. Measured concentration levels in the atmosphere surrounding the Baltic Sea drainage basin are too sporadic (*especially from a historical perspective*) to serve in defining these boundary conditions. Since the model results show a high sensitivity to the boundary conditions, we have chosen to evaluate the model using three different scenarios for these ratios in the simulations. These are:

- BC<sub>0</sub>:** All ratios are set to zero. This scenario implies that there is no inflow of HCHs from outside regions to the model domain.
- BC<sub>1</sub>:** All ratios are set to one. This scenario assumes that the inflow of HCHs equals the outflow (*i.e. the model boundary acts like an inert wall, returning all HCH molecules leaving the model area*).
- BC<sub>opt</sub>:** Optimised ratios are defined as functions of time. This option represents a “best estimate” for the five ratios.

Some additional explanation may be required on how these optimised ratios were derived. The approximate magnitude of this fraction/multiple as a function of time was estimated based on:

- (1) The relative magnitude of the surface area-normalised usage estimates in the regions within and adjacent to the model domain.
- (2) The relative magnitude of air and sea water concentrations measured within and adjacent to the model domain.

The atmospheric advection rates have a direct impact on the estimated ratios describing the boundary conditions. The tentative ratios, developed as described above, had to be scaled individually to reflect the magnitude of the applied advection rates. The likely range of the ratios was estimated by running the model and comparing the results with measured air and seawater concentrations within the model domain. Finally, the ratios of each individual region were then scaled separately to optimise the fit between measured and modelled concentrations. In this third option, the boundary conditions were thus treated as a tunable

parameter. Although it has been proven difficult to define and justify the exact values applied, the former two model scenarios ( $BC_1$ ,  $BC_0$ ) are included in part to provide the reader with two transparent reference states for comparison purposes.

## 5. Evaluation of model results

The model was evaluated by comparing the predicted concentrations with data reported in the literature. Numerous studies have been devoted to studying the levels of HCHs in various environmental media of the Baltic Sea environment during the past three decades (e.g. Gaul, 1992; Jensen et al., 1992; Bignert et al., 1998). Whereas many measured data are available for the atmosphere and seawater, data in sediments and the terrestrial environment were sparse. No data could be found for concentrations in soils. The focus of the comparison was on the absolute concentration levels, on the spatial and temporal concentration patterns in various media and biota. In general, the predicted concentrations in various media tend to be within the same order of magnitude as the measured concentrations for both HCH isomers and often within a factor of two.

### 5.1 Spatial concentration patterns

Spatial concentration patterns are being evaluated by comparison with measurements in seawater, marine sediments and foliage.

#### 5.1.1 Seawater

One of the few studies describing the spatial distribution of HCHs in the entire Baltic Sea was reported by Gaul (1992), who measured surface sea water concentrations at various locations within the Baltic Sea during two campaigns in May/June 1983 and 1988 (Gaul, 1992). He noted higher levels of HCHs in the Baltic Proper than in the Skagerrak, which he attributed to low water exchange rates. Concentrations of HCHs in the surface water of the Skagerrak flowing out of the Baltic Sea were higher than in the inflowing bottom water. In order to compare measured data with model estimates, we assigned the data from Gaul (1992) to the corresponding aquatic compartment. The average concentration within each compartment was then compared with the model estimate. The model results correspond to the time period when the samples were taken. The results, which are sensitive to the specified boundary conditions, are presented in Figure 5 and suggest a fair agreement between modelled ( $BC_{opt}$ ) and observed concentrations.

The model predicts slightly higher concentrations of  $\alpha$ -HCH towards the Northern and Eastern reaches of the Baltic Sea with highest concentrations in the Gulf of Finland. However, the highest concentrations were measured in seawater of the Bothnian Bay and the Bothnian Sea. Although the discrepancies are minor for  $\alpha$ -HCH, the results may indicate that the usage and inflow of  $\alpha$ -HCH via fresh water and surface run-off to the Gulf of Finland are overestimated for the early 1980s. This might have obscured the observed gradient of increasing concentrations of  $\alpha$ -HCH with increasing latitude in the Baltic Sea, which mirrors what was observed for the Northern hemispheric oceans as a whole (Wania and Mackay,

1996). As is shown in Figure 5a, the model does not predict reasonable  $\alpha$ -HCH concentrations with the assumption of no inflow ( $BC_0$ ).

For  $\gamma$ -HCH, the observed concentrations are virtually uniform east of the Danish Straits for both 1983 and 1988. For these regions, only the model settings with the optimised boundary conditions ( $BC_{opt}$ ) are capable of reproducing the observed values, indicating showing that the assumption of inflow equals outflow ( $BC_1$ ) does not succeed in reproducing the observed levels in surface sea water. The uniform concentrations as well the underestimation of measured concentrations (*except*  $BC_{opt}$ ) are further considered as an indication that sea water levels may be dominated by atmospheric inputs, rather than direct discharges from agricultural areas.

The seawater concentrations predicted for the Danish Straits and the Kattegat are too low. Since measured concentrations tend to be lower in the seas to the east and west of these straits (Gaul, 1992), we suggest that this may be caused by an underestimation of lindane usage in Southern Sweden, Denmark and Northern Germany, leading in turn to an underestimation of either or both the discharge from rivers and soils from adjacent agricultural areas and the atmospheric deposition to these seas.

### 5.1.2 Sediments

Spatial patterns of  $\alpha$ -HCH and  $\gamma$ -HCH concentrations in sediments of the southwestern parts of the Baltic Sea have been reported by the Bundesamt für Seeschifffahrt und Hydrographie (BSH, 1991) and Dannenberger and Lerz (1996). The data from the Kattegat and the southern Baltic Proper in 1987 represent a few locations only (BSH, 1991), whereas the concentrations in sediments (0-2 cm depth) from the Danish Straits represent several locations and may thus be considered more representative (Dannenberger and Lerz, 1996). The data from Kattegat and the Baltic Proper are from 1987, while the Danish Straits were sampled during autumn 1993 and 1994. However, many of the samples from the Danish Straits were taken close to the shoreline, and may have been strongly influenced by local riverine inputs of HCHs. The data in Table 2 are thus difficult to compare, but they suggest that measured concentrations of both isomers are highest in the sediments of the Danish Straits, which agrees with the sea water concentrations in this part of the Baltic Sea (Figure 5). The measured sediment concentrations in the Danish Strait are however surprisingly high, considering that the samples were taken 6 or 7 years after those from Kattegat and the Baltic Proper.

When comparing measured and modelled values for the Danish Straits we see that the model underestimates the observed values of  $\alpha$ -HCH, and that the assumption of  $BC_1$  provides the best agreement between measured and observed values. For  $\gamma$ -HCH, both  $BC_{opt}$  and in particular  $BC_1$  are in accordance with observed sediment concentrations in 1987. Further we observe that  $BC_{opt}$  results in a fair agreement for the sediment concentrations of  $\gamma$ -HCH in the Danish straits in 1993/94.

Figure 5: Comparison between measured surface water concentrations and model estimates for  $\alpha$ -HCH (a) and  $\gamma$ -HCH (b) during the summer of 1983 and 1988.

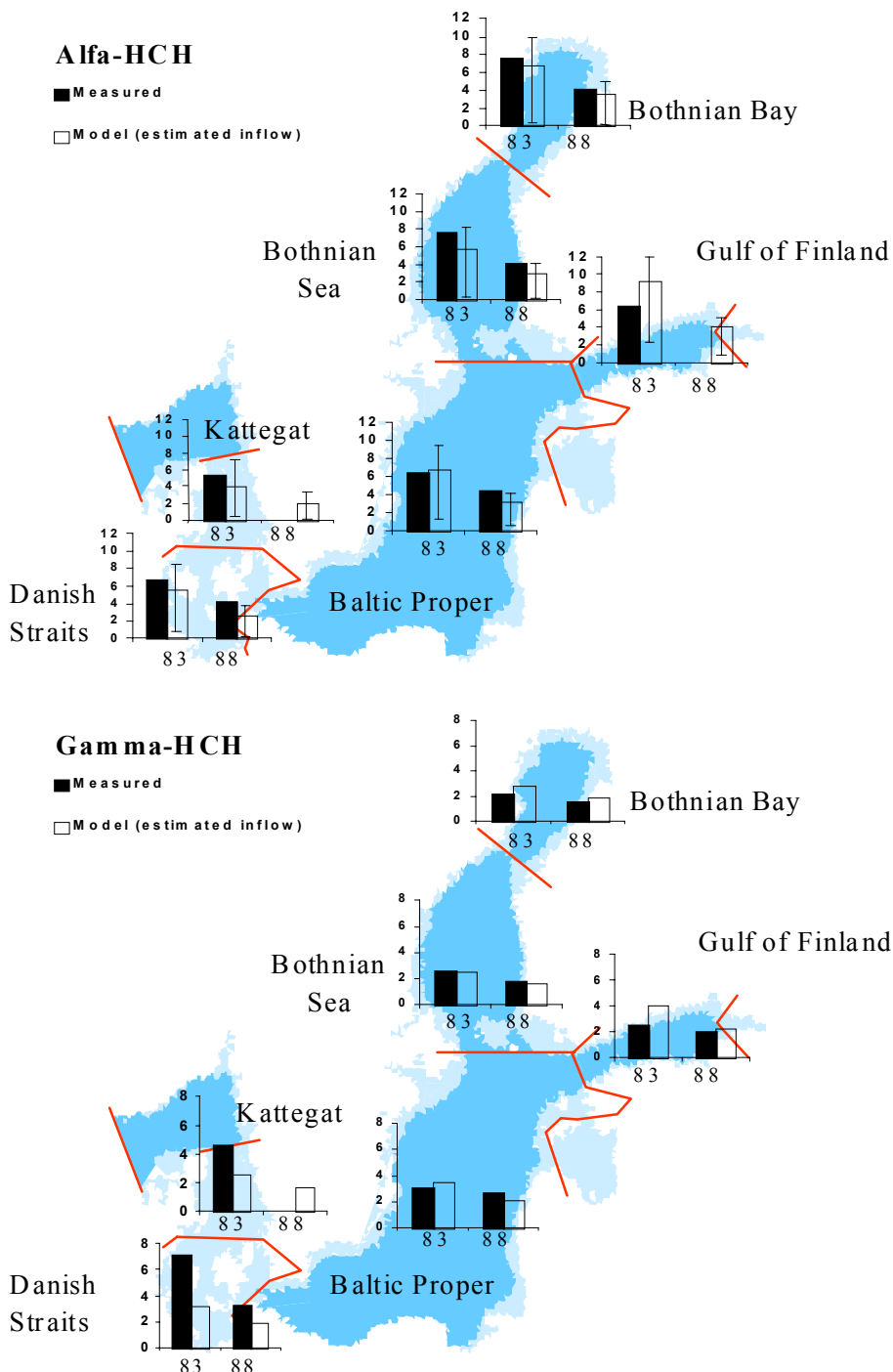

For  $\alpha$ -HCH and  $\gamma$ -HCH the empty bars represents the model settings with estimated inflow ( $BC_{opt}$ ). For  $\alpha$ -HCH, the influence of treating the boundary conditions as an inert wall ( $BC_1$ ) and the assumption of no inflow ( $BC_0$ ) are depicted with high values for the former and low values for the latter. For  $\gamma$ -HCH, the model estimates presented ( $BC_{opt}$ ) are in all cases higher than  $BC_1$  and  $BC_0$ .

Table 2: Comparison between modeled and measured sediment concentrations<sup>1</sup>

ng/kg d.w.	$\alpha$ -HCH			$\gamma$ -HCH		
	Kattegat Sept. 87	Da. Straits* Sept. 93/94	Baltic Prop. Sept. 1987	Kattegat Sept. 87	Da. Straits* Sept. 93/94	Baltic Prop. Sept. 87
<b>Meas average</b> (range) n	<b>49</b> (22-109) 4	<b>198</b> (9-1890) 17	<b>66</b> (12-138) 3	<b>100</b> (45-210) 4	<b>207</b> (14-1531) 20	<b>133</b> (63-207) 3
Model (BC <sub>1</sub> )	345	171 / 135	442	102	77 / 64	127
Model (BC <sub>0</sub> )	15	9 / 8	51	11	10 / 8	25
Model (BC <sub>opt</sub> )	198	113 / 91	311	136	181 / 161	165

<sup>1</sup> Model estimates from the Danish straits refer to 1993 and 1994, respectively.

### 5.1.3 Needles

Elevated deposition velocities to forest canopies as compared to bare soil and grassland led to the development and implementation of a forest compartment in multi-media mass balance models (Wania and McLachlan, 2001). The POPCYCLING-Baltic model contains a seasonally dependent mixed forest canopy compartment, based on information on the fractions of coniferous and deciduous forests in each of the ten terrestrial environments (Figure 4a). Processes such as diffusive gas exchange, dry particle and wet deposition processes are taken into account, as are degradation in the canopy and litterfall fluxes. However, the main incentive of including a forest compartment in the model is to account for the effect of the forest on the overall chemical fate rather than the prediction of foliage concentrations.

Pine needles have been utilised to monitor spatial distribution patterns of POPs, including the HCHs, in Europe (Eriksson et al., 1989). A direct comparison is not feasible because the model calculates the fresh weight concentrations of a mixed (*coniferous plus deciduous*) forest compartment. Studies with sampling in the Baltic Sea drainage basin report the wax concentrations of coniferous needles (Eriksson et al., 1989) or dry weight concentrations (Calamari et al., 1994). Strachan et al. (1994) showed that there was a marked difference between concentrations expressed for the wax alone and levels given for the residual needle. We have thus chosen to compare the model with results from this latter study. Pine needles, representing various year classes from Lumsås, Denmark (*T8 Danish Straits*) and Dorotea, Sweden (*T2 Bothnian Sea*) were sampled during April 1989, analysed for the total content of  $\alpha$ -HCH and  $\gamma$ -HCH (*wax plus interior*), and reported on a fresh weight basis (Strachan et al. 1994). The values in Table 3 are recalculated from Strachan et al. (1994) to yield total concentrations in pine needles. Generally, an increase in the total concentration of HCHs as well as the wax fraction was found as the needles aged (Strachan et al. 1994).

Table 3: Comparison between modeled and measured pine needle concentrations.

ng/g (fresh weight)	$\alpha$ -HCH		$\gamma$ -HCH	
	Danish straits	Bothnian Sea	Danish Straits	Bothnian Sea
<b>Measured average</b>	<b>2.37</b>	<b>5.70</b>	<b>1.76</b>	<b>2.06</b>
(range) n	(0.84 – 5.00) 6	(0.90 – 9.65) 4	(0.69 – 3.24) 6	(0.36 – 3.47) 4
Model (BC <sub>1</sub> )	2.67	4.28	0.89	1.32
Model (BC <sub>0</sub> )	0.04	0.07	0.04	0.04
Model (BC <sub>opt</sub> )	1.66	2.82	2.40	2.88

range and n represent various age classes of pine needles

Neglecting the model results representing the clearly unreasonable assumption of no inflow (BC<sub>0</sub>), we see that there is a fairly good agreement between measured and modelled values. Interestingly, the model captures the spatial differences with higher concentrations in the northern region as was observed for both isomers. This difference was more pronounced for  $\alpha$ -HCH, which again is reflected in the model results. Elevated concentrations of  $\alpha$ -HCH and  $\gamma$ -HCH in pine needles from the Northern part of the Baltic Sea drainage basin seems also to be reflected in the data from Jensen et al. (1992). These data (*not shown*) cover an area from the southern parts of France, up to the northernmost part of Sweden. However, high concentrations of HCHs were also found in the southern parts of Europe, which was attributed to the proximity to areas of heavy usage (Jensen et al. 1992). We further note that the estimated boundary conditions (BC<sub>opt</sub>) yield figures for  $\alpha$ -HCH that are too low when compared to the measured values, and that the measured values of  $\gamma$ -HCH fall in between the model results obtained with BC<sub>1</sub> and BC<sub>opt</sub>.

## 5.2 Concentration time trends

One of the main incentives for developing the POPCYCLING-Baltic model was to address the environmental time response to loading reductions. The performance of the model in that respect needs to be evaluated through a comparison between observed and simulated time trends. Concentrations measured in the atmosphere, seawater and fish were used for this purpose.

### 5.2.1 Atmosphere

Concentrations of HCHs in air from the Baltic Sea drainage basin, specifically Southern Norway, were measured as early as 1981 (Oehme and Manø, 1984). A few years later, Bidleman et al. (1987) reported concentrations of HCHs in air in southern Sweden. Around 1990, monitoring stations measuring HCH air concentrations became operational in the southern parts of Norway and Sweden. A total of 337 measured concentration values for the western atmospheric compartment were aggregated and are shown in Figure 6 together with the calculated concentration time trends. Non-aggregated data for 1994 and 1995 are

plotted in Figure 7, showing the seasonal pattern of measured air concentrations at the coastal stations in Lista, Norway (Haugen et al. 1998) and Rörvik, Sweden (Brorström-Lundén, 1995;1996).

Whereas the assumption of no inflow ( $BC_0$ ) obviously yields erroneous results, the other two boundary conditions give results that are very similar to the observed ones. The model performs better for  $\alpha$ -HCH than  $\gamma$ -HCH, possibly because its air concentrations are less controlled by ongoing usage within the drainage basin than by temperature-driven re-emissions from environmental reservoirs within and outside of the model domain. Modelled  $\gamma$ -HCH concentrations are somewhat low, in particular during the spring and summer period. This indicates that the air concentrations being influenced by current usage of lindane. This is also seen for  $\gamma$ -HCH in Figure 7B. Elevated concentrations of  $\gamma$ -HCH at these coastal station have been attributed to long-range transport from the South-western parts of Europe, using back-trajectories to trace the origin of the air masses of individual samples (Brorström-Lunden, 1996; Haugen et al., 1998). Deviations for  $\gamma$ -HCH are higher in the early 1990s, i.e. the air concentrations are not decreasing as fast as the model predicts. This may reflect the use of stockpiles after bans on the sale of lindane came into effect. Finland banned lindane usage in 1987 (AMAP, 1998), Germany in 1988 (UNEP, 1995) and Sweden in 1989 (AMAP, 1998).

### 5.2.2 *Sea Water*

Gaul (1992) reported time trends for surface sea water concentrations from the Baltic Proper from 1975 to 1990. For  $\alpha$ -HCH, a decrease in the measured concentrations during that time period had occurred, but no clear trend was detected for  $\gamma$ -HCH. These data are compared with model estimates in Figure 8 using the three different boundary conditions. For both  $\alpha$ - and  $\gamma$ -HCH there is a fairly good agreement between measured and modelled concentrations, except for the scenario with no inflow of HCHs from outside the model domain ( $BC_0$ ). The model captures the observed values somewhat better when optimised boundary conditions are used ( $BC_{opt}$ ) than if it is assumed that inflow equals outflow ( $BC_1$ ). For  $\alpha$ -HCH the latter setting ( $BC_1$ ) overestimates the pre-1985 concentrations, while the same setting for  $\gamma$ -HCH underestimates the post-1983 concentrations. The discrepancies are however small, and the data on technical HCH usage for the period prior to 1985 are very uncertain (Breivik et al. 1999), and possibly too high. During the period from the mid-1980s until 1990, the model under-predicts  $\gamma$ -HCH concentrations, i.e. predicts a decrease in concentrations in sea water, whereas the measured data are inconclusive. This is similar to the situation in the atmosphere.



Figure 6: Modelled and observed concentrations of  $\alpha$ -HCH and  $\gamma$ -HCH in the western atmospheric compartment (data compiled in Pacyna et al. 1999).

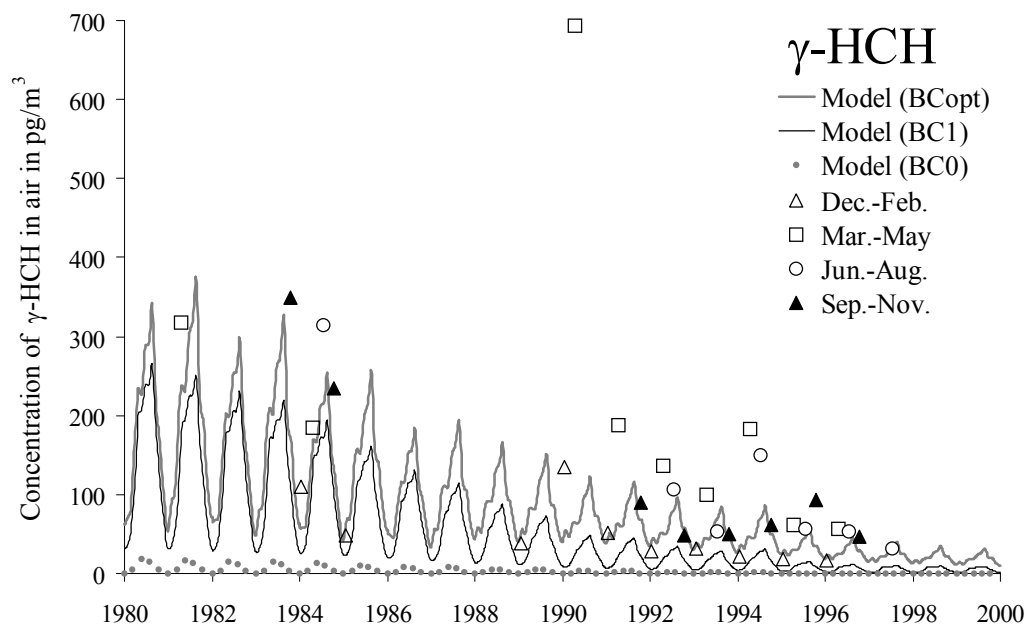
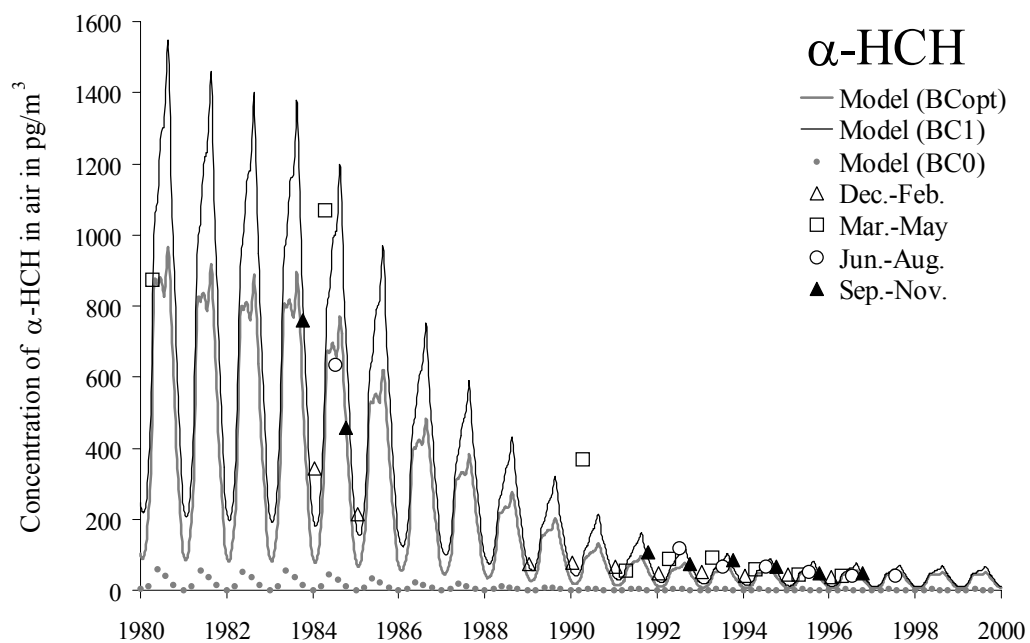

Figure 7: Seasonal variation of modelled and observed 1994 & 1995 concentrations of  $\alpha$ -HCH and  $\gamma$ -HCH in the western atmospheric compartment in 1994 and 1995. Data from Lista are from haugen et al. 1998 and the data from Rörvik are from Brorström-Lundén (1995, 1996).

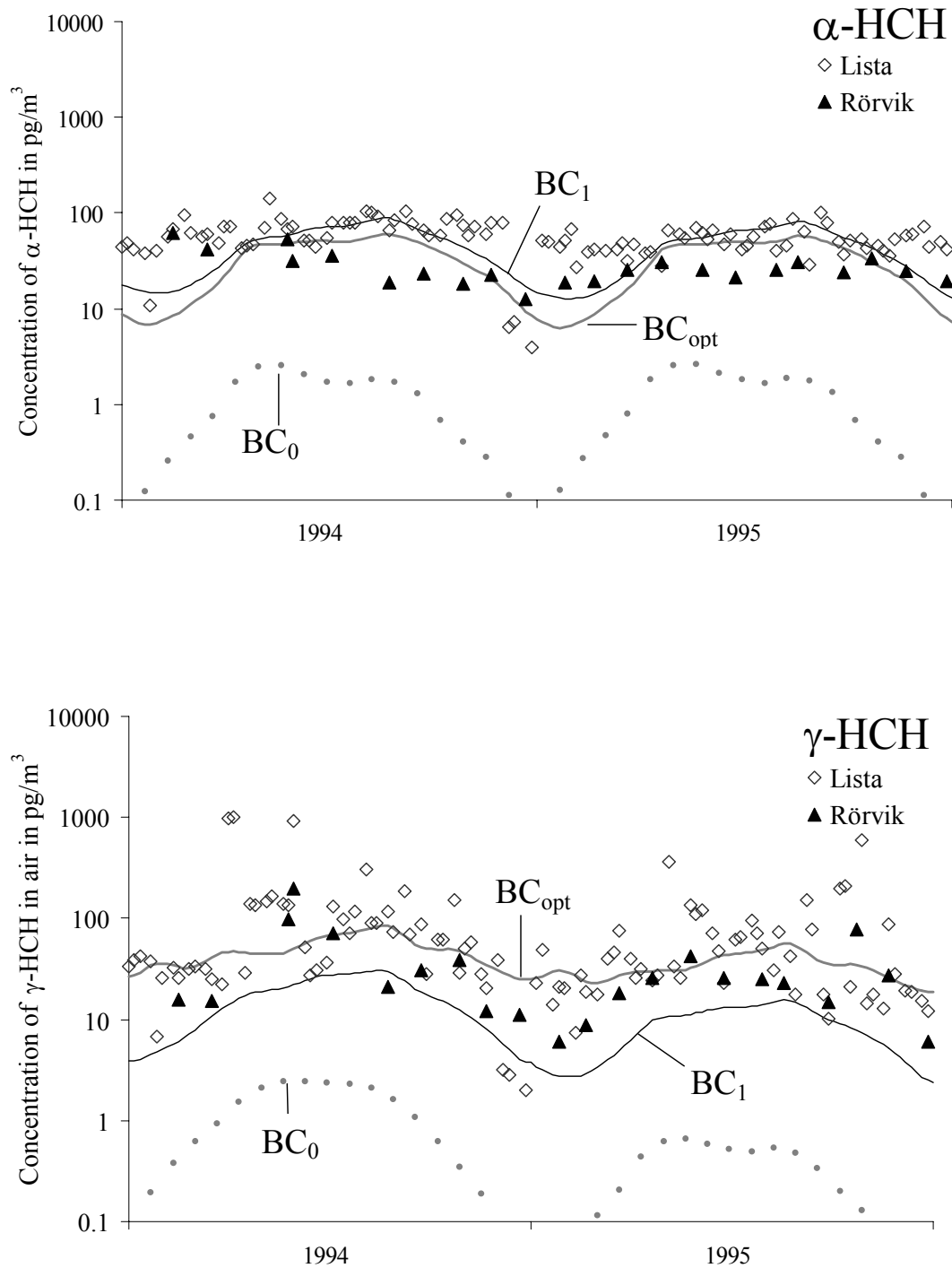
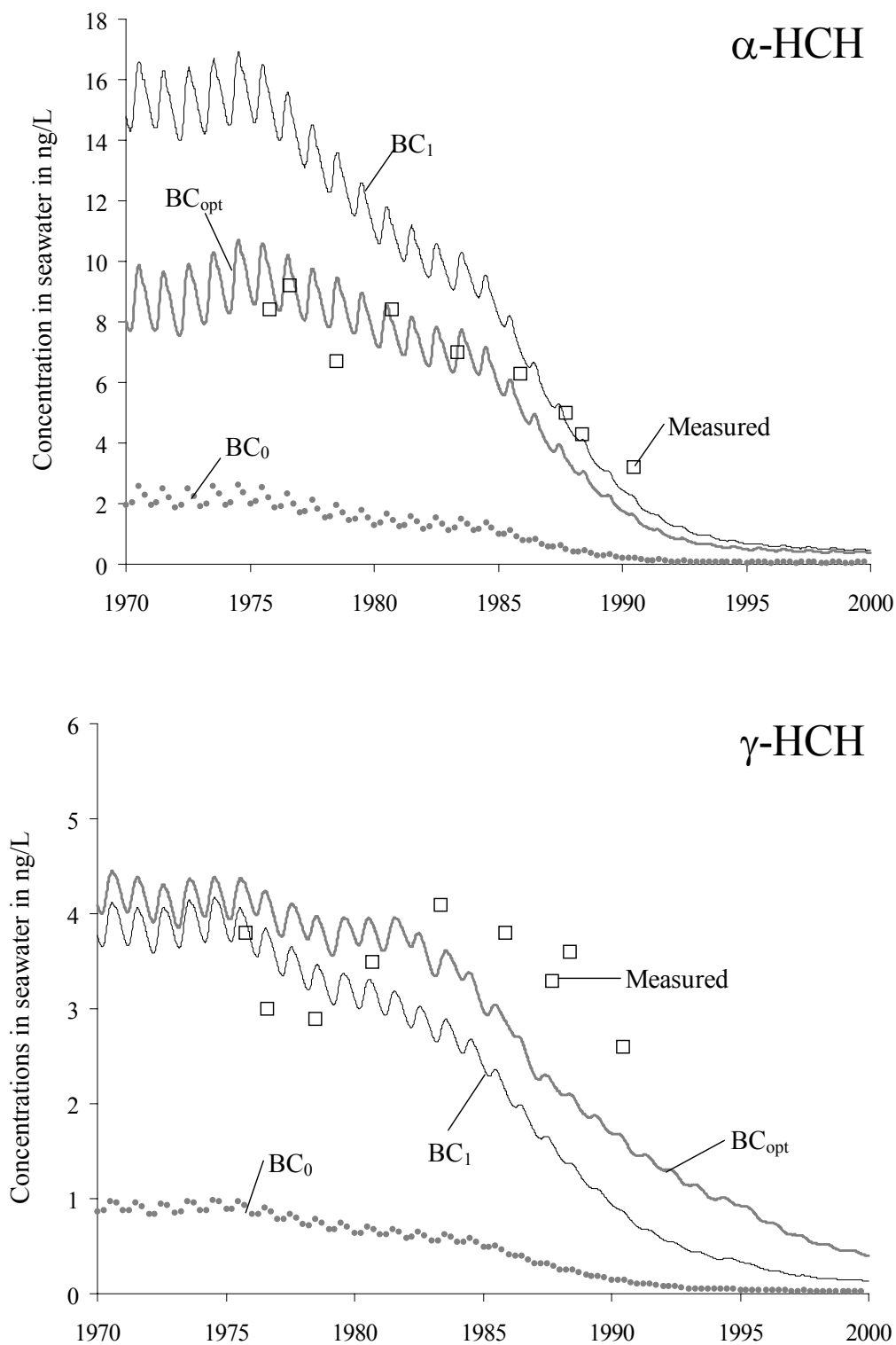

Figure 8: Modelled and observed concentrations of  $\alpha$ -HCH (A) and  $\gamma$ -HCH (B) in the surface seawater of the Baltic Proper. Data from Gaul (1992).



### 5.2.3 Comparison with time-trends in fish

Bignert et al. (1998) reported temporal trends in the concentrations of various POPs, including  $\alpha$ -HCH and  $\gamma$ -HCH, in fish from fresh and coastal seawater in the Swedish part of the Baltic Sea environment. The pattern in these observed time-trends was earlier found to be comparable to the trend in usage data for Sweden and adjacent countries (Breivik et al. 1999). Although the POPCYCLING-Baltic model does not predict concentrations in fish, it is not unreasonable to assume that the observed temporal trends of HCHs in fish reflect the trends in the respective water compartments. A comparison between modelled concentrations in water and measured concentrations in fish may thus provide additional insight whether the model captures the observed trends in relative terms.

The longest HCH time trend presented by Bignert et al. (1998) is for pike from Lake Storvindeln in Northern Sweden. This lake is located in the southernmost part of the terrestrial model region of the Bothnian Bay (*see Error! Reference source not found.*). Since there is little agricultural activity in this region, atmospheric deposition is likely dominating the input of HCHs to the lake. Modelled freshwater concentrations and observed concentrations in pike are overlain in Figure 9, indicating that the observed and measured trend of  $\alpha$ -HCH resemble each other fairly well. The concentrations of  $\alpha$ -HCH in pike shows a strong interannual variations during the first half of the period, even though the fish are always collected during the same season. During the 1970s and into the 1980s significant technical HCH usage occurred at some distance in the countries to the south and east of Northern Sweden. There may have been large interannual variability in the amounts used during those years, which are not captured in the emission estimates. Also, atmospheric delivery to the lake is likely influenced by the particular weather conditions during the pesticide application period, and large interannual variations in delivery efficiency to Northern Sweden are possible. The model, using smooth release data and long-term averaged atmospheric advection rates, cannot capture such variations. Starting in the late 1980s, both the levels in pike and modelled fresh water concentrations level off and stabilise.

The situation for  $\gamma$ -HCH (Figure 9B) is rather different, both in terms of modelled concentrations and observed levels in pike. There is no distinct trend in pike concentrations that can be detected over the time period. During the late 1970s, some fairly high levels were recorded, which may at least in part be attributable to interannual fluctuations in long-range transport and deposition to this remote lake. The model also calculates a temporary peak in fresh water concentrations, but this peak occurs a few years later than was observed for pike.

Bignert et al. (1998) also investigated the content of HCHs in herring at various sites along the coastal seawaters of Sweden. These data are restricted to the time-period between 1987 and 1997. We have chosen to compare these data with the coastal water concentrations of  $\alpha$ -HCH and  $\gamma$ -HCH calculated for the corresponding model regions (C1, C2, C7, C9 – *see Error! Reference source not found.*) for the same time as the samples were taken. These data are summarised in Figure 10. For simplicity, we are only presenting a comparison between measured concentrations in herring and the model setting with optimised boundary conditions (BC<sub>opt</sub>). It is encouraging to observe that a fair relationship can be observed, although some scatter is evident. This comparison confirms that

from 1987 to 1997 the herring concentrations have decreased in a similar fashion as the predicted coastal water concentrations.

## 6. Application of the model for pathway and flux analysis

During the model evaluation, the calculated concentrations were found sensitive to the applied boundary conditions, i.e. the assumptions concerning the exchange of HCH across the model boundaries. Whereas the model did not perform well under the assumption of no inflow of HCHs from outside the model domain, two other settings for the boundary conditions gave reasonable agreements between modelled and measured values. These were BC<sub>1</sub>, a scenario for which the inflow concentrations of HCHs were assumed equal to the outflow concentrations, and BC<sub>opt</sub>, a scenario for which the boundary conditions were scaled and optimised based on usage and concentration differences between the model domain and the surrounding regions. In the following analysis, only results obtained using the scenario with optimised boundary conditions (BC<sub>opt</sub>) are presented. An identical analysis, using scenario BC<sub>1</sub> was performed. Even though the calculated fluxes varied as a result of the choice of boundary conditions, the overall conclusion was found to remain the same. The model evaluation had identified small discrepancies between modelled and observed concentrations that are likely due to uncertain emission estimates. However, these deviations were not deemed large enough to justify an adjustment of the independently derived emission rates by Breivik et al. (1999).

The drainage basin of the Baltic Sea in the POPCYCLING-Baltic model is divided into ten different terrestrial/coastal systems (**Error! Reference source not found.**). These environmental systems differ markedly with respect to the loading and usage patterns of HCHs, the land cover, as well as the prevalent climatic conditions. Three of these regions were selected to illustrate some of the differences in fate that HCHs encountered within different region within the Baltic Sea drainage basin.

(1) The Bothnian Bay is the northernmost region of the Baltic Sea, characterised by a cold climate, low consumption of lindane, and negligible usage of technical HCH. The terrestrial/coastal system includes parts of Sweden and Finland, covers an area of about  $2.88 \cdot 10^5$  km<sup>2</sup>, and consists of forests (66.3%), agricultural lands (24.4%), fresh water (4.1%) and coastal water (5.2%).

(2) The Gulf of Riga region has experienced an estimated high historical usage of technical HCH and its coastal water body is characterised by relatively limited water exchange with the rest of the Baltic Sea. Its terrestrial/coastal system extends over an area of  $1.55 \cdot 10^5$  km<sup>2</sup> with forests (33.7%), agricultural lands (54.0%), fresh water (1.7%) and coastal water (10.7%) and includes parts of Latvia and Lithuania as well as smaller areas of Estonia, Belarus and Russia. The lack of observations and the uncertain release estimates make the results for this region quite uncertain and should be interpreted with caution.

(3) The Danish Straits are a terrestrial/coastal system with a relatively high historical consumption of lindane. It covers an area of  $0.48 \cdot 10^5$  km<sup>2</sup> with forests (4.2%), agricultural lands (52.2%), fresh water (1.3%) and coastal water (42.3%). Observed environmental concentrations are most readily available for this region, which consists of parts of Denmark, Sweden and Germany.

Figure 9: Comparison between modelled freshwater concentrations in the Bothnian Bay and observed concentrations of  $\alpha$ -HCH and  $\gamma$ -HCH in pike from Lake Storvindeln. Data from Bignert et al. (1998).

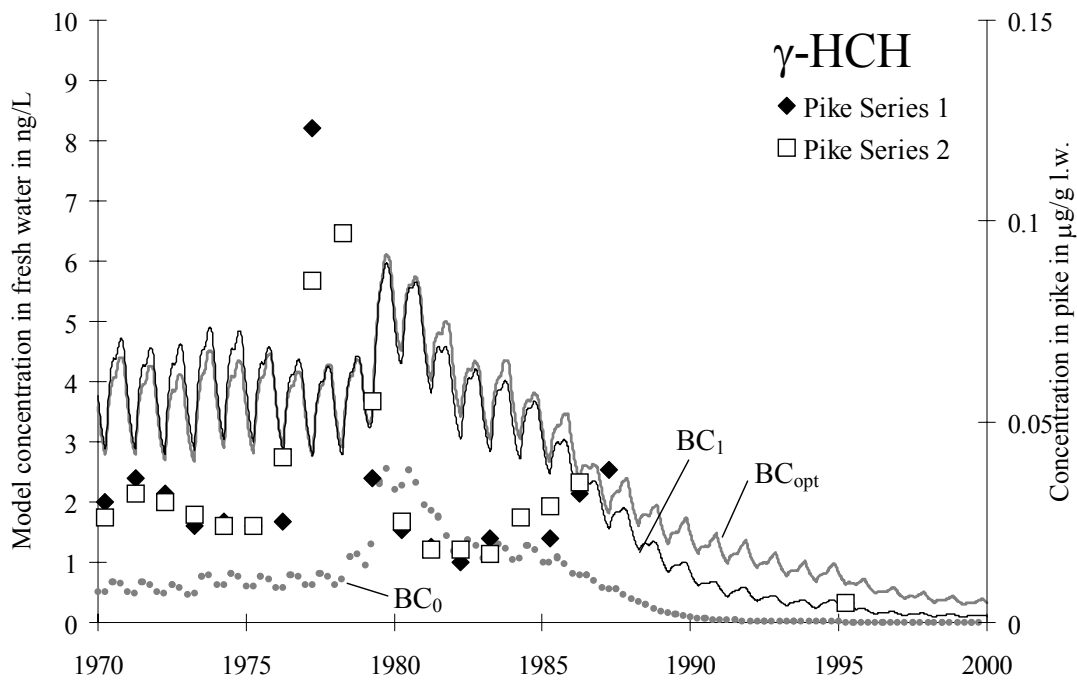
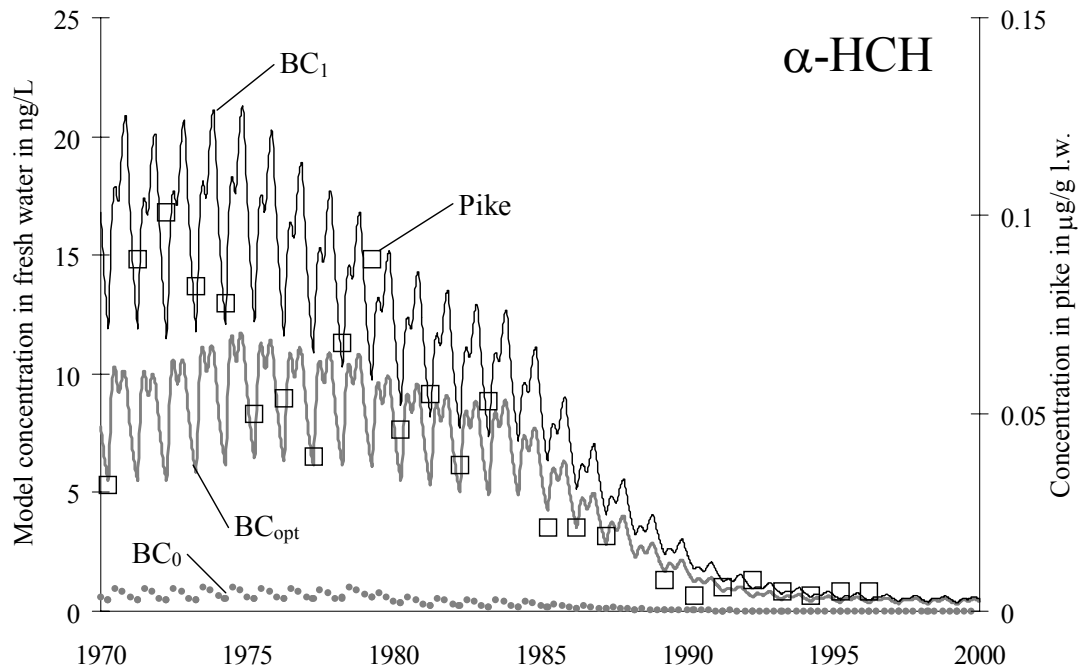
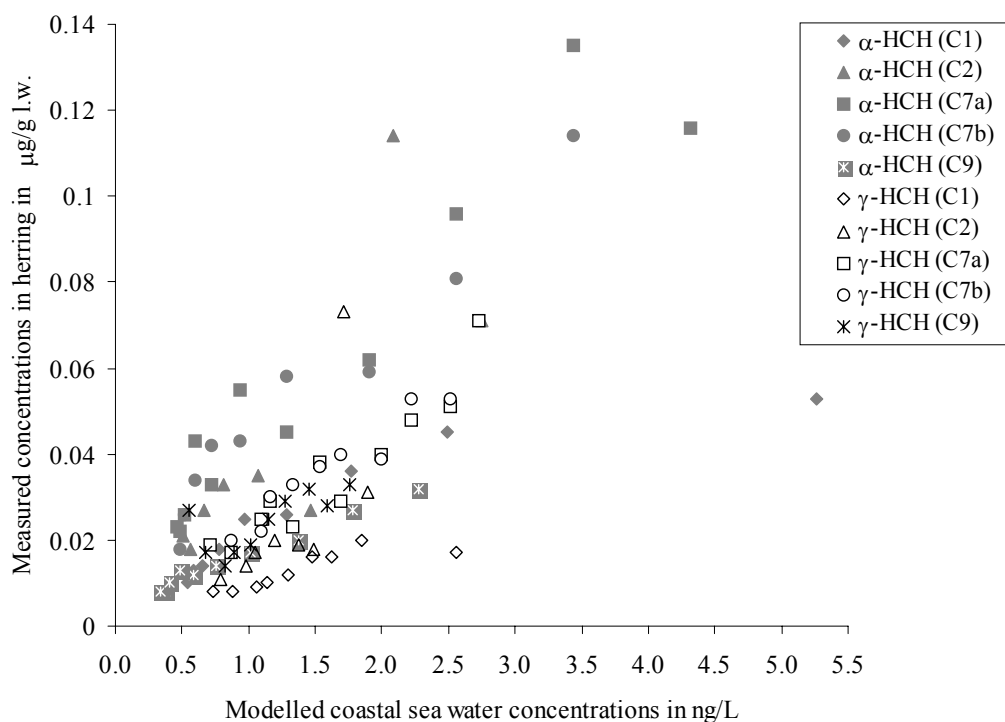

Figure 10: Comparison between modelled coastal seawater concentrations ( $BC_{opt}$ ) and observed concentrations of  $\alpha$ -HCH (grey) and  $\gamma$ -HCH (open) in herring, 1987-1997. Data from Bignert et al. (1998).



- C1: Data from Harufjärden compared to model results from C1 – Bothnian Bay  
 C2: Data from Ängskärsklubb compared to model results from C2 – Bothnian Sea  
 C7a: Data from Landsort compared to model results from C7 – Swedish Baltic Proper  
 C7b: Data from Utlängan compared to model results from C7 – Swedish Baltic Proper  
 C9: Data from Fladen compared to C9 - Kattegat

### 6.1 Sources of HCH within and outside of the Baltic Sea drainage basin

One of the key questions related to the occurrence of HCHs in the Baltic Sea environment, is to what extent the observed levels can be explained by usage within the drainage basin and what fraction is due to advective inflow of chemical used beyond the boundaries of the drainage basin. The cumulative historical usage of technical HCH and lindane in the Baltic Sea drainage basin from 1970 until 2000 was estimated to be 28 471 and 494 tonnes, respectively. Using the average isomeric content of technical HCH (67.7%  $\alpha$ -HCH, 14%  $\gamma$ -HCH) and lindane (100%  $\gamma$ -HCH) from Breivik et al. (1999), this corresponds to a historical consumption of 19.3 kt of  $\alpha$ -HCH and 4.5 kt of  $\gamma$ -HCH. These data suggest that almost 4 kt of  $\gamma$ -HCH applied in the Baltic region arise from the consumption of technical HCH, or that only 11% of the historical consumption of  $\gamma$ -HCH were caused by lindane usage in the basin.

The model calculates that within the same 30 years 29.4 kt of  $\alpha$ -HCH and 9.7 kt of  $\gamma$ -HCH were advected into the drainage basin in the atmosphere. Another 0.5 kt  $\alpha$ -HCH and 0.6 kt of  $\gamma$ -HCH entered the model domain with seawater advected into the Skagerrak from the North Sea (Figure 11). The model thus suggests that direct usage within the Baltic Sea drainage basin accounts for about 30 to 40 percent of the total amount of HCHs entering this environment. The remainder is due to usage outside of the drainage basin. This is not surprising, as HCHs are known to have a high potential for long range atmospheric transport. This focus on the gross transport rates may however be somewhat misleading because the outflow of HCH from the model domain is in the same order of magnitude as the influx (Figure 11). In fact the model suggests that the Baltic Sea drainage basin as a whole has been a net exporter of  $\alpha$ -HCH.

According to the model, the relative importance of sources within the drainage basin has generally decreased in time. When a similar analysis as shown in Figure 11 is performed for individual five-year periods, it becomes obvious that the contribution of  $\alpha$ -HCH from within drainage basin use has decreased from about 45 percent in the early 70s to less than 25 percent during the 1990s. Nevertheless, the region was a net exporter of  $\alpha$ -HCH during the whole time period. In the case of  $\gamma$ -HCH, the contribution from sources within the drainage basin even decreased from 40 to 10 percent. During the 1980s, the Baltic Sea region switched from being a net exporter of  $\gamma$ -HCH, to being a net recipient of  $\gamma$ -HCH, to a situation where inflow more or less equals outflow. When evaluating these model results, it is imperative to keep in mind that the amount being transported by air masses across the model boundary is critically dependent on the applied boundary conditions and their changes in time. However, an analysis with boundary conditions BC<sub>1</sub> supports these conclusions, but the figures are different.

*Figure 11: Model estimate of the relative importance of  $\alpha$ -HCH and  $\gamma$ -HCH emitted within the Baltic Sea environment and HCH being advected from surrounding regions.*

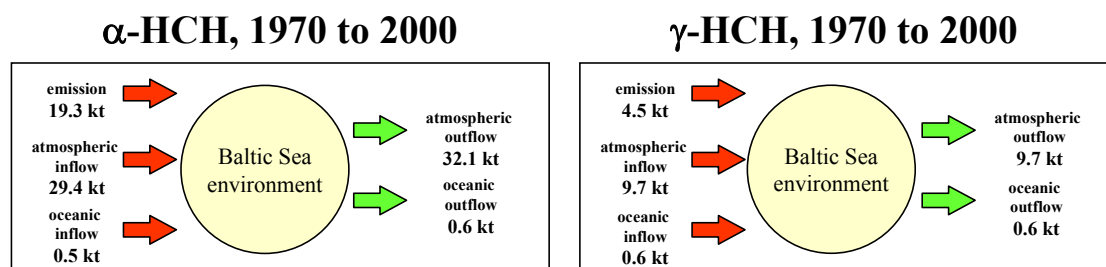

When transport between the four atmospheric compartments is taken into consideration, it becomes obvious that different regions within the Baltic Sea drainage basin behave differently. Figure 12 shows the calculated amounts of HCHs being advected into, within, and out of the four atmospheric compartments.



The results indicate that

- (1) usage has been substantially higher in the South and East than in the West and North, the difference being most pronounced for  $\alpha$ -HCH,
- (2) in the western and northern region, the amounts of HCHs being applied within the model regions are generally smaller than the fluxes being advected by air masses, and
- (3) the western and northern atmospheric regions have been net recipients, the southern and eastern atmospheric regions net exporters of HCHs.

Figure 12: Cumulative atmospheric advection rates for  $\alpha$ -HCH and  $\gamma$ -HCH from 1970 to 2000 in thousand tonnes. Values in parentheses give the historical environmental release within each region, values in square brackets indicate the estimated net atmospheric exchange (inflows minus outflows).

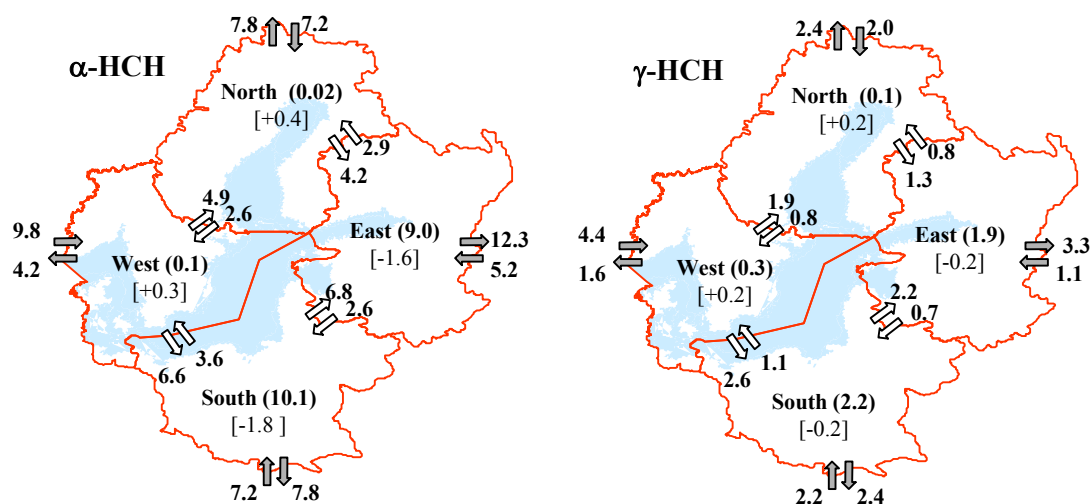

## 6.2 Pathways within the marine environment of the Baltic sea

Within the Baltic Sea drainage basin, it is of considerable interest to assess the relative importance of the atmospheric versus the riverine pathways for the delivery of HCHs to the Baltic Sea ecosystem. Figure 13 presents the calculated, cumulative  $\alpha$ -HCH and  $\gamma$ -HCH fluxes within the Baltic Sea for the time period from 1970 to 2000. For each coastal and open water compartment the atmospheric depositional, volatilisation, and riverine flux of the HCHs are presented. There is no riverine inflow to the open water compartments, and it is assumed that no direct emission of HCHs to the marine water compartments takes place. Also given are the transport fluxes between the seawater compartments.

The model suggests that the atmospheric pathway is more important than the riverine flux in delivering  $\alpha$ - and  $\gamma$ -HCH to most coastal systems. Atmospheric input becomes even more dominant, when the input pathways to the various sub-basins (*coastal plus open water*) or the Baltic Sea as a whole are being assessed (Table 4). For  $\gamma$ -HCH, the delivery by riverine inflow seems to be somewhat more important than for  $\alpha$ -HCH. This may in part be explained by the fact that  $\gamma$ -HCH

is more water-soluble and less volatile than  $\alpha$ -HCH. In regions of higher technical HCH usage (e.g. *Gulf of Riga, Southern Baltic Proper and Neva*) the relative influence of the riverine fluxes increases. This implies that there is an increasing relative importance of the riverine pathway as we move from the western to the eastern part of the Baltic Sea.

*Table 4: Relative importance (in percent) of riverine inflow and atmospheric deposition for the input of HCHs to various parts of the Baltic Sea.*

	$\alpha$ -HCH	$\alpha$ -HCH	$\gamma$ -HCH	$\gamma$ -HCH
	Atmospheric deposition	Riverine inflow	Atmospheric deposition	Riverine inflow
Bothnian Bay	90	10	80	20
Bothnian Sea	96	4	93	7
Gulf of Finland	78	22	68	32
Gulf of Riga	56	44	52	48
Baltic Proper	87	13	88	12
Danish Straits	98	2	93	7
Kattegat	95	5	89	11
Skagerrak	95	5	91	9
Baltic Sea	87	13	85	15

In almost all compartments the cumulative net flux across the air water interface has been depositional. Exceptions are the Neva for  $\alpha$ - and  $\gamma$ -HCH and the Gulf of Riga for  $\alpha$ -HCH, which reflects the high input in the vicinity of these water bodies. We will explore below whether the direction of air-water exchange has changed during the model period.

Figure 13: Cumulative inter-basin fluxes of  $\alpha$ -HCH (A) and  $\gamma$ -HCH (B) in the Baltic Sea in tonnes, 1970 – 2000.

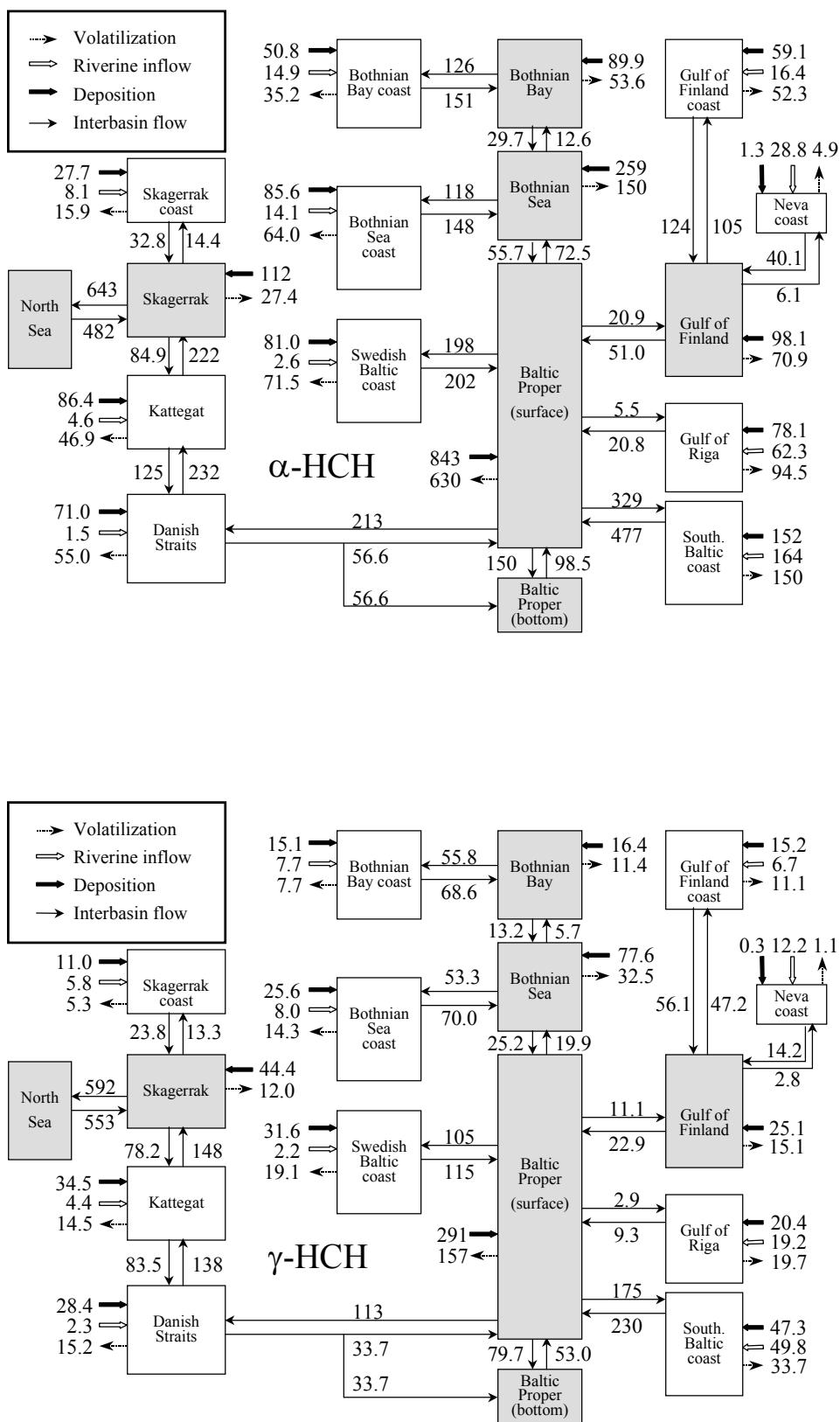

An inspection of the advection rates within water reveals that for both HCHs the net transfer is always from the coastal to the open water systems. This reflects both the net flux of water from the coastal to the open water compartments and the higher concentrations in the coastal waters caused by the additional input from the rivers. The interbasin advection rates show that HCHs is transferred from the innermost parts through the Baltic Proper and out towards the North Sea. This is again a reflection of the net flux of water within the Baltic Sea system (HELCOM, 1986). The exchange rates between the North Sea and the Skagerrak are highly dependent on the choice of boundary condition. However, both scenarios for the boundary conditions between the Skagerrak region and the North Sea suggest a situation close to steady-state with outflow fluxes being fairly similar to the inflow fluxes. For  $\gamma$ -HCH, this is a reflection of the higher usage of lindane towards the south and south-west of the drainage basin (Breivik et al. 1999). Measurements of HCHs in seawater within and outside the Baltic Sea (Gaul, 1992) indicate that there has indeed been a net outflow of HCHs out of the basin throughout most of the modelled time-period.

It is interesting to compare these HCH input fluxes with the intercompartmental exchange rates among the marine compartments. In many cases, such as the Bothnian Bay and Sea or the Gulf of Finland, the exchange rates between coastal and open water compartments are larger than the fluxes across the air-water interface. This suggests that a mixing within the basins is relatively rapid, and the distinction of coastal and open water regions is only justified for fairly short-lived chemical species. The exchange between the major sub-basins of the Baltic Sea on the other hand, tends to be smaller than the exchange in the vertical direction, justifying the multiple compartment approach. The closer the water compartments to the North Sea, the greater the importance of water advection. Advection rather than transport by rivers and atmospheric deposition dominate HCH fate in the Danish Straits and the Kattegat. This had already been noted for the behaviour of PCBs in the Baltic Sea (Wania et al. 2001).

### **6.3 Temporal trends in emissions and accumulated amounts**

It is possible to use the model to investigate how the total amounts present in the selected terrestrial/coastal regions have changed over time and how this corresponds to the temporal changes in HCH emissions within these regions. For the time period from 1970 until 2000 Figure 14 plots the total annual emission rate and the total accumulated amount of  $\alpha$ - and  $\gamma$ -HCH within the three selected regions introduced in the methods section. Whereas in the Danish Straits region the annual usage of both isomers is roughly the same as the total accumulated amount (Figure 14 C and F), the annual HCH usage in the Gulf of Riga area is about twice what is present in the environment (Figure 14 B and E). In the Bothnian Bay region, on the other hand, the annual usage is merely a small fraction of the total amount for  $\alpha$ -HCH (Figure 14 A and D). In source regions the temporal trend of the total accumulated amount follows closely the temporal trend of the annual emission, but the correlation is weak in remote areas. In particular, the temporal trends of emission and amount are essentially identical in the Gulf of Riga, and there is a fairly strong correlation in the Danish Straits. In the Bothnian Bay, however, there is only a vague relationship between the emission and the amount of HCHs found in the environment. This identifies the

Gulf of Riga as a region where HCH behaviour is almost completely controlled by local emissions and the potential for loss by degradation and advection elsewhere. In the Bothnian Bay region, HCH fate is largely governed by atmospheric transport and deposition, and the Danish Straits are somewhere in the middle.

Figure 14: Total accumulated amounts and total annual emission rate of  $\alpha$ - and  $\gamma$ -HCH in three selected sub-regions of the Baltic Sea environment (Bothnian Bay, Gulf of Riga and Danish Straits) from 1970 to 2000.

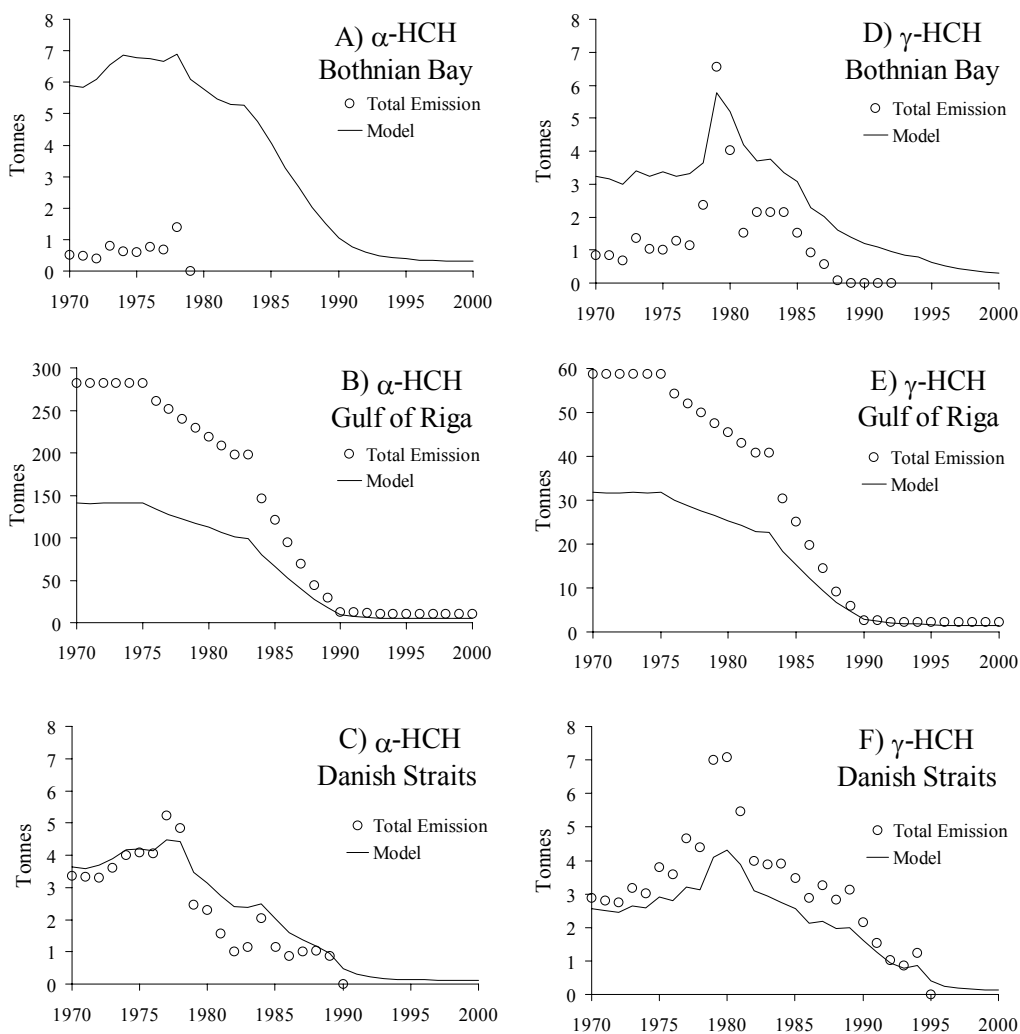

#### 6.4 Reservoirs within the drainage basin of the Baltic Sea

The model further allows an assessment of the distribution of the HCHs among environmental compartments as a function of time. As this distribution is very dependent on emissions and environmental characteristics, it is again presented for the three selected sub-regions (Figure 15). Agricultural soils constitute the major environmental reservoir during periods of active usage of HCH-containing pesticides in a region. The Gulf of Riga region has seen technical HCH usage during the entire simulation period, and agricultural soils completely dominate as the most important environmental reservoir for both isomers within this region (>70 %) (Figure 15B and E). The situation is similar in the Danish Straits region, except that the drainage basin is relatively small compared to the size of the coastal basin and a notable fraction of the HCHs is found in the coastal water compartment. The share found in agricultural soils relative to that in the coastal water compartment is directly related to the emission rate, being higher for  $\gamma$ -HCH than for  $\alpha$ -HCH, and rapidly decreasing as the usage of HCHs ceased in this region (Figure 15C and F). The HCHs are much more evenly distributed among the various environmental compartments of the Bothnian Bay region, which received HCHs mostly through atmospheric transport from elsewhere. Namely, more than about half of the HCHs partitions into the forests (*canopy and soils*) that cover a large area in this region (Figure 15A and D). The air and sediment compartments contribute little to the total amount in any region.

A relatively large usage of lindane around 1979 in the Bothnian Bay drainage basin allows to explore the shifts in compartmental distribution occurring as a result of such temporary emission peaks. In that particular year, the total annual consumption of  $\gamma$ -HCH exceeded the total amount present in the environment of this region (Figure 14 D) and agricultural soils became temporarily the dominant compartment with more than 50% of the total amount present (Figure 15D). In the years thereafter, continuing lindane usage maintained the role of agricultural soils as the principal pool of  $\gamma$ -HCH until 1987. After 1988, forests became again the most important compartment as a result of the sudden decrease in lindane consumption in Finland and Sweden and the increasing relative importance of long-range atmospheric transport.

#### 6.5 Pathways within the drainage basin of the Baltic Sea

The discussion about various environmental reservoirs revealed substantial differences among regions. The differences in emissions and environmental characteristics should also be reflected in differences in the relative importance of various fluxes and processes. Figure 16 presents the cumulative fluxes and process rates for  $\alpha$ -HCH in the three regions to highlight some of these differences. The various rates have been scaled according to the cumulative overall emission rate within the entire Baltic Sea drainage basin in order to facilitate the comparison of the relative importance of various processes (*a value of 100 corresponds to 1 % of the total amount of an HCH isomer emitted in the Baltic Sea environment from 1970 to 2000*). As the overall historical behaviour shows many similarities between the two isomers within these regions, we have chosen to restrict the results and discussion to  $\alpha$ -HCH. Similar figures for  $\gamma$ -HCH are however presented in Figure 17.

Figure 15: Calculated relative distribution of  $\alpha$ - and  $\gamma$ -HCH among the various compartments of three selected sub-regions of the Baltic Sea environment (Bothnian Bay, Gulf of Riga and Danish Straits) from 1970 to 2000.

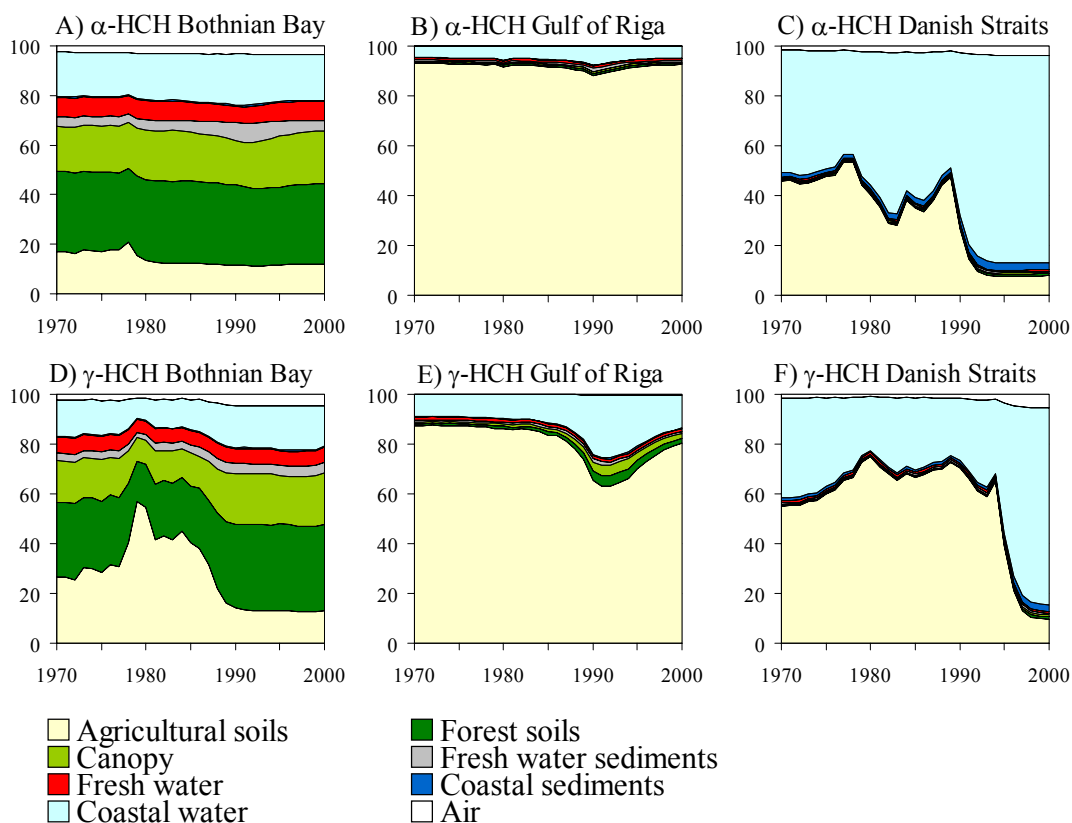

The historical consumption and release of  $\alpha$ -HCH has been estimated to be 19 275 tonnes within the entire Baltic Sea drainage basin in the period from 1970 to 2000. Six tonnes has been applied in the Bothnian Bay, 51 tonnes in the Danish Straits, and 4120 tonnes in the Gulf of Riga. Large atmospheric fluxes are indicative of the importance of the atmosphere as an efficient medium for transport and dispersion. The model predicts a net atmospheric outflow for the Gulf of Riga, and a net inflow for the Bothnian Bay and Danish Straits regions. In the Bothnian Bay region, the atmospheric fluxes are about three orders of magnitude higher than the historical consumption rate of  $\alpha$ -HCH, and even the net atmospheric import is about 30 times higher than the consumption rate within the basin. In the Danish Straits region net atmospheric inflow and consumption have been in the same order of magnitude, while the net atmospheric export from the Gulf of Riga region is only about 10 percent of the consumption rate.

Figure 16: Cumulative fluxes of  $\alpha$ -HCH in three selected sub-regions of the Baltic Sea environment (Bothnian Bay, Gulf of Riga and Danish Straits) from 1970 to 2000. The figures are scaled according to the historical consumption within the entire basin (see text).

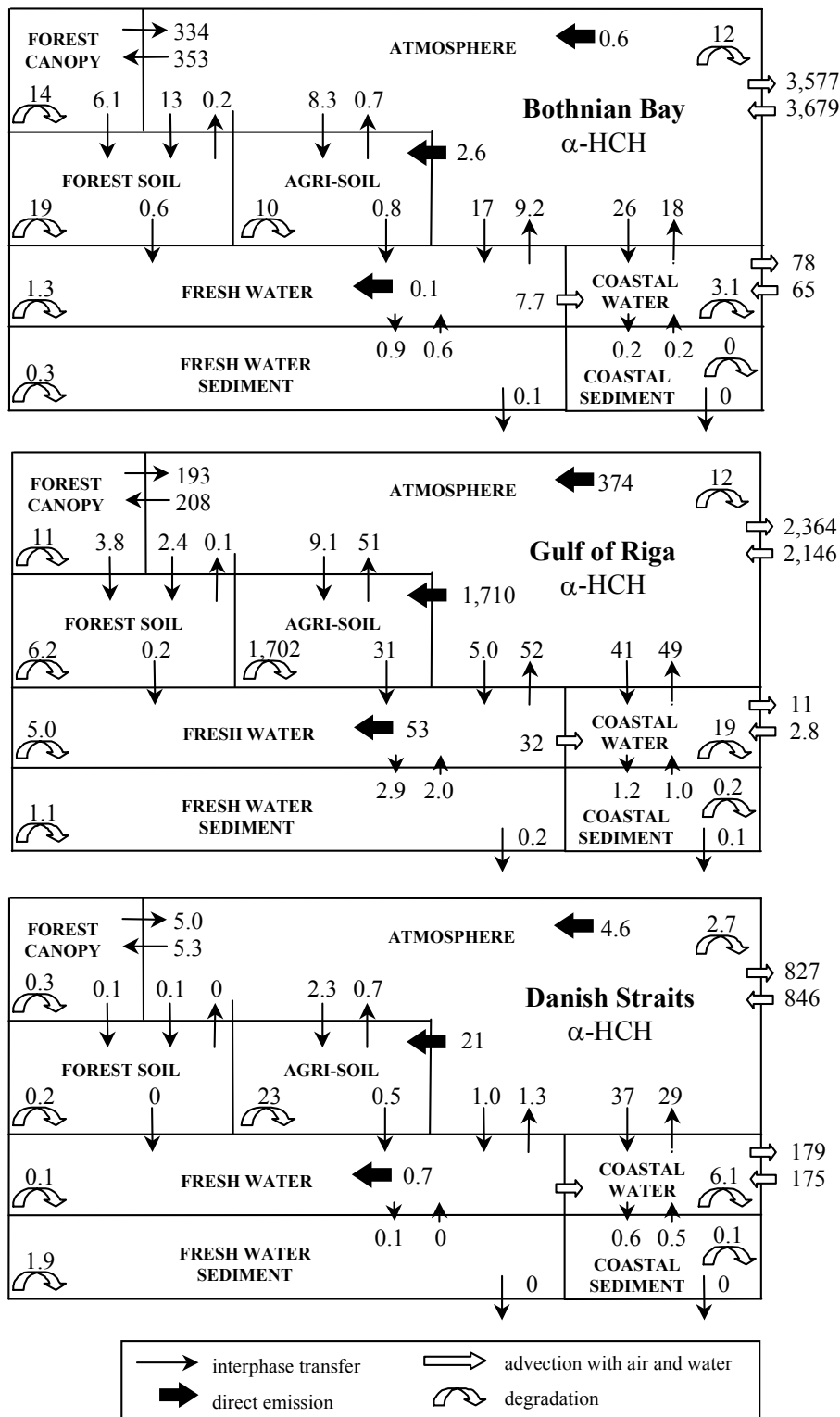
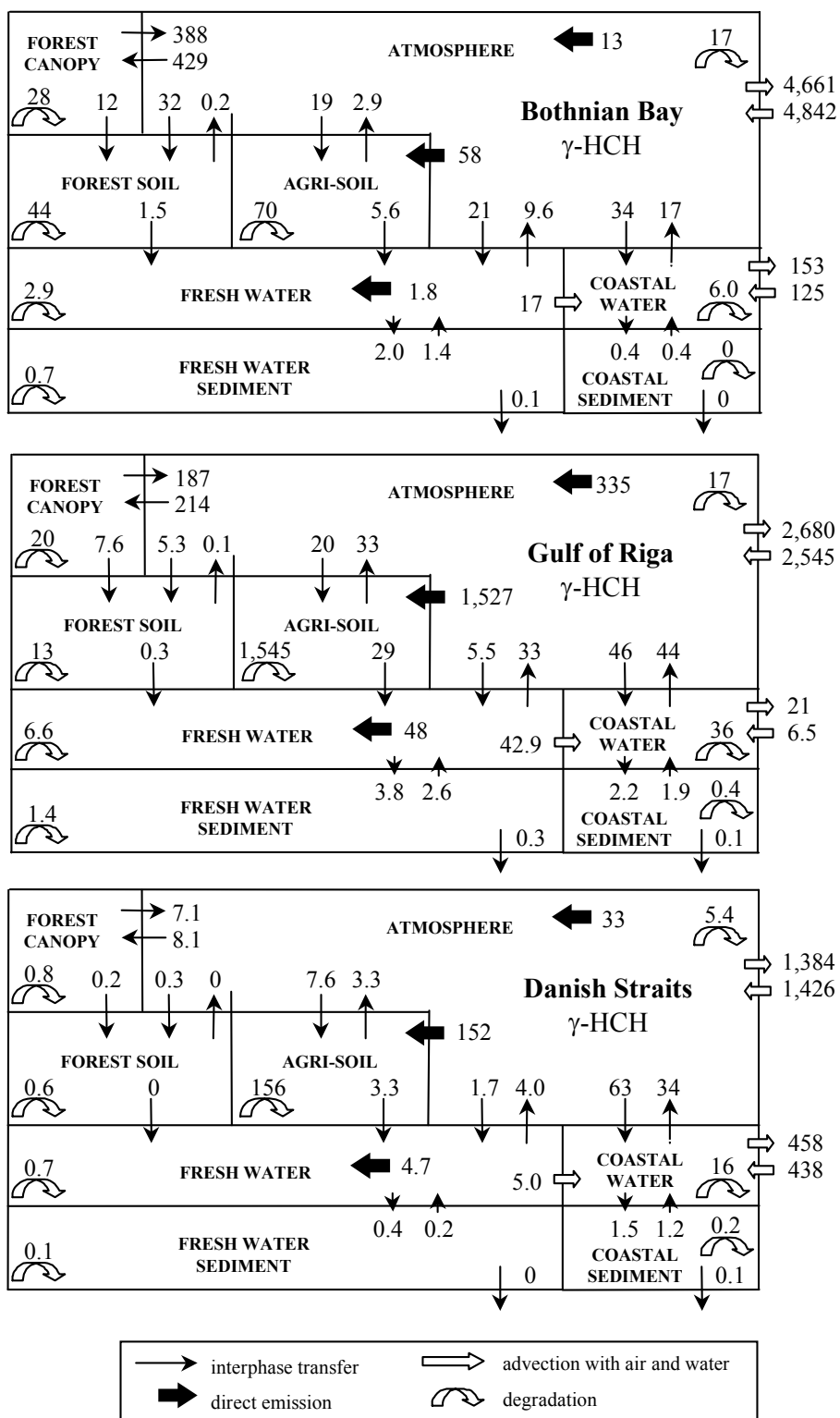



Figure 17: Cumulative fluxes of  $\gamma$ -HCH in three selected sub-regions of the Baltic Sea environment (Bothnian Bay, Gulf of Riga and Danish Straits) from 1970 to 2000. The figures are scaled according to the historical consumption within the entire basin (see text).



The bulk of the HCH being used never leaves the site of application and is degraded within agricultural soils. For example, 17 percent of the total amount of  $\alpha$ -HCH used within the Baltic Sea environment, has been emitted to the agricultural soils of the Gulf of Riga region, and about the same amount has been lost by degradation in these soils. This importance of degradative loss in the soils of application was also found when modelling the fate of  $\alpha$ -HCH globally (Wania and Mackay, 1999b). It is thus all the more noteworthy that the relatively small fraction of the HCH that is mobilised from the sites of application, was sufficient to cause widespread contamination in the range of nanograms per liter of water and per cubic meter of air. In this respect, we also note the significant role that remote areas such as the Bothnian Bay play in the environmental fate of the HCHs. More than half a percent of the total cumulative emission of  $\alpha$ -HCH has been degraded within the Bothnian Bay region (*mostly in the terrestrial environment*), which is more than what is degraded in the Gulf of Riga region in media other than the agricultural soils.

While air-surface exchange with the forest system is depositional in all three investigated regions, they differ with respect to the balance of the exchange fluxes with other surface compartment. In the Gulf of Riga, the volatilisation flux of  $\alpha$ -HCH from agricultural soils, and fresh and coastal water compartments exceeds the depositional flux. Volatilisation and depositional fluxes are very similar in the Danish Straits region but overall indicate a net deposition. There is clearly a net deposition of  $\alpha$ -HCH to all surface compartments in the Bothnian Bay environment. The latter may in part be attributed to colder temperatures in the North which result in reduced volatilisation and degradation. These differences are an element in the translocation of HCHs from source areas to remote areas within the drainage basin via atmospheric transport.

The fluxes associated with fresh and coastal water sediments are predicted to be small when compared to the fluxes between the atmosphere and terrestrial and aquatic surfaces. The model results further indicate that the degradation losses in fresh and coastal water are higher than the corresponding sedimentation flux. Sediments are not important as a final sink for the HCHs.

Regional environmental conditions have an impact on the relative importance of pathways within various regions. A regional feature with an impact on HCH fate is the semi-enclosed nature of the Gulf of Riga. Its water residence time has been estimated to be about five and a half years, which makes it the most isolated of all the sea water compartments in the model (Wania et al. 2000). Coastal outflow thus is a minor loss process for  $\alpha$ -HCH in the Gulf of Riga when compared to the other two coastal basins. Combined with a significant amount of  $\alpha$ -HCH being delivered to coastal waters in this region through rivers, the Gulf of Riga shows the highest degradation rate in coastal water among the sub-basins, both in terms of amount degraded per time and per area (*data not shown*). HCHs may experience a “trapping” effect in the coastal waters of the Gulf of Riga, resulting in the relatively elevated concentrations (*see* Wania, 1999b).

In another example of the influence of regional environmental conditions, we note that forests play a significant role within the Bothnian Bay area, but are of no importance in the Danish Straits region. This is due both to the large area covered by forests in the former region, and the low temperatures favouring deposition to the land surface. Even though the predicted fluxes associated with the forest canopies are high, the amounts being released again to the air after initial deposition are also high, showing that the forest canopy acts as a temporal storage compartment (Wania and McLachlan, 2001). The model further predicts that the concentrations in foliage in the Bothnian Bay, was approximately twice the concentration in the Danish Straits in 1970 (*data not shown*) and indicates that this concentration difference has almost disappeared at the end of the simulation period.

### 6.6 Atmosphere-surface equilibrium status and flux direction

In response to the historical reductions in the use and accompanying primary emissions of lindane and technical HCHs, several studies have been addressing the potentially increasing importance of secondary emissions, i.e. the mobilisation of HCHs from environmental reservoirs such as large water bodies, soils and sediments. For example, field studies observed a change from net atmospheric deposition to net evaporation from Arctic Ocean water in response to loading reductions to the atmosphere (e.g. Bidleman et al. 1995). The POPCYCLING-Baltic model is based on the fugacity approach (Mackay, 1991) and can calculate the temporal development of the equilibrium status between two media in contact with each other. When contamination levels in adjacent compartments are expressed in terms of fugacity, the levels can be compared directly and the chemical flux direction can be predicted from the fugacity gradient. A chemical will move from media with high fugacity to those with low fugacity. When the fugacity of a given chemical in adjacent compartments is equal, chemical equilibrium is established. We prefer the use of fugacity fractions instead of the more commonly employed fugacity ratios. In the case of air-surface equilibrium these fractions are defined as:

$$FF = f_{\text{Atmosphere}} / (f_{\text{Atmosphere}} + f_{\text{Surface medium}}) \quad (1)$$

FF can assume values between 0 and 1. Equilibrium is indicated by a value of 0.5 and deviations from equilibrium in either direction are depicted on the same scale. In the context of air-surface exchange, a fugacity fraction of larger than 0.5 implies a net deposition, a value below 0.5 net volatilisation. In this study we apply fugacities and fugacity fractions to investigate the historical fluxes of  $\alpha$ -HCH and  $\gamma$ -HCH between various compartments.

To illustrate the use of fugacities and fugacity fractions in the interpretation of the fate of HCHs, we discuss the results for the same three basins mentioned above. An analysis of the time trend of the fugacities of  $\alpha$ -HCH and  $\gamma$ -HCH in the atmosphere and the surface media of these three regions (Figure 18, page 42 and Figure 19, page 43, respectively) reveals the following:

- (1) The fugacities are higher in source areas than in remote areas.  $\alpha$ -HCH fugacities are higher in the Gulf of Riga,  $\gamma$ -HCH fugacities are higher in the Gulf of Riga and Danish Straits.
- (2) At any point in time, the fugacities of the HCHs in the media of one region are within a fairly small range, typically within two to three orders of magnitude. This range tends to be somewhat larger in source areas (*i.e. Gulf of Riga*) than in remote areas (*i.e. Bothnian Bay*). This indicates a fairly high mobility of the HCHs. High intermedia transport capabilities prevent large deviations from an equilibrium distribution. The lowest fugacities tend to be associated with the forest soils, the highest with the agricultural soils and the fresh water compartments, which are the recipients of environmental HCH releases.
- (3) The fugacities in all media decrease as a result of the loading reductions that have occurred during these three decades. The rate of decrease is similar within the various media, although there are subtle differences. Most notably the fugacities in the agricultural soils appear to drop more rapidly once emissions have ceased. This will become more obvious later when we investigate fugacity relationships between pairs of media.
- (4) The fugacities in all media show a strong seasonal variability. This is caused by the strong impact of temperature on the partitioning properties between the gas phase and condensed phases such as water, soil and foliage.

An analysis of the fugacity fractions between air and the various surface media (Figure 20, page 44 for  $\alpha$ -HCH, Figure 21, page 45 for  $\gamma$ -HCH) allows us to make the following observations:

- (1) Fugacity fractions notably below 0.5, indicative of volatilisation, occur only for agricultural soils and fresh water compartments in source areas (Gulf of Riga for  $\alpha$ - and  $\gamma$ -HCH, Danish Straits for  $\gamma$ -HCH). When emissions cease, e.g.  $\gamma$ -HCH release in the Danish Straits during 1990s, reversal of air-surface exchange occurs rapidly and these media change from being sources to being recipients of airborne HCH.
- (2) Forest canopy and coastal water compartments tend to be always close to equilibrium with the atmosphere. This is a reflection of fast atmosphere-surface exchange with these media, which thus quickly adjust to changes in atmospheric conditions. Often seasonal cycles of deposition and volatilisation develop, caused by the changes in air-water equilibrium (*Henry's law constants*) as influenced by the seasonal variations in air and coastal water temperatures. The fugacity fraction increases during winter and decreases during summer indicating that the propensity for volatilisation is highest during summer.
- (3) Forest soils are always relatively far from equilibrium, indicating that the depositional transfer to the forest soil is not sufficiently rapid to fill the large potential soil reservoir. After deposition, the HCH tends to be degraded fairly rapidly. This is also true for agricultural soils after emissions have ceased (*e.g. both HCHs in the Danish Straits after 1995*).

### **6.7 Water-sediment equilibrium status and flux direction**

The fugacity fractions between water compartments and their underlying sediments as a function of time tend to be close to 0.5, indicating relatively fast water-sediment equilibration (Figure 22, page 46 and Figure 23, page 47). For  $\alpha$ -HCH an interesting temporal trend is observable in all three regions. During times of significant  $\alpha$ -HCH release, fresh water sediments were net recipients of  $\alpha$ -HCH, whereas the marine sediments were in equilibrium with their respective water compartments. As  $\alpha$ -HCH usage during the late 1980s and early 1990s declined, the fugacity in water dropped faster than fugacity in sediments and all these sediments have temporarily become sources of  $\alpha$ -HCH, releasing the chemical back into the water phase. After a few years, the sediment reservoir of  $\alpha$ -HCH has been depleted and an equilibrium situation is again established by the late 1990s. A similar situation occurred for  $\gamma$ -HCH in the Gulf of Riga. Also, release of  $\gamma$ -HCH from the sediments in the Danish Straits occurred after lindane was no longer used in this area.

Figure 18: Fugacities of  $\alpha$ -HCH calculated for selected compartments of the POPCYCLING-Baltic model from 1970 to 2000.

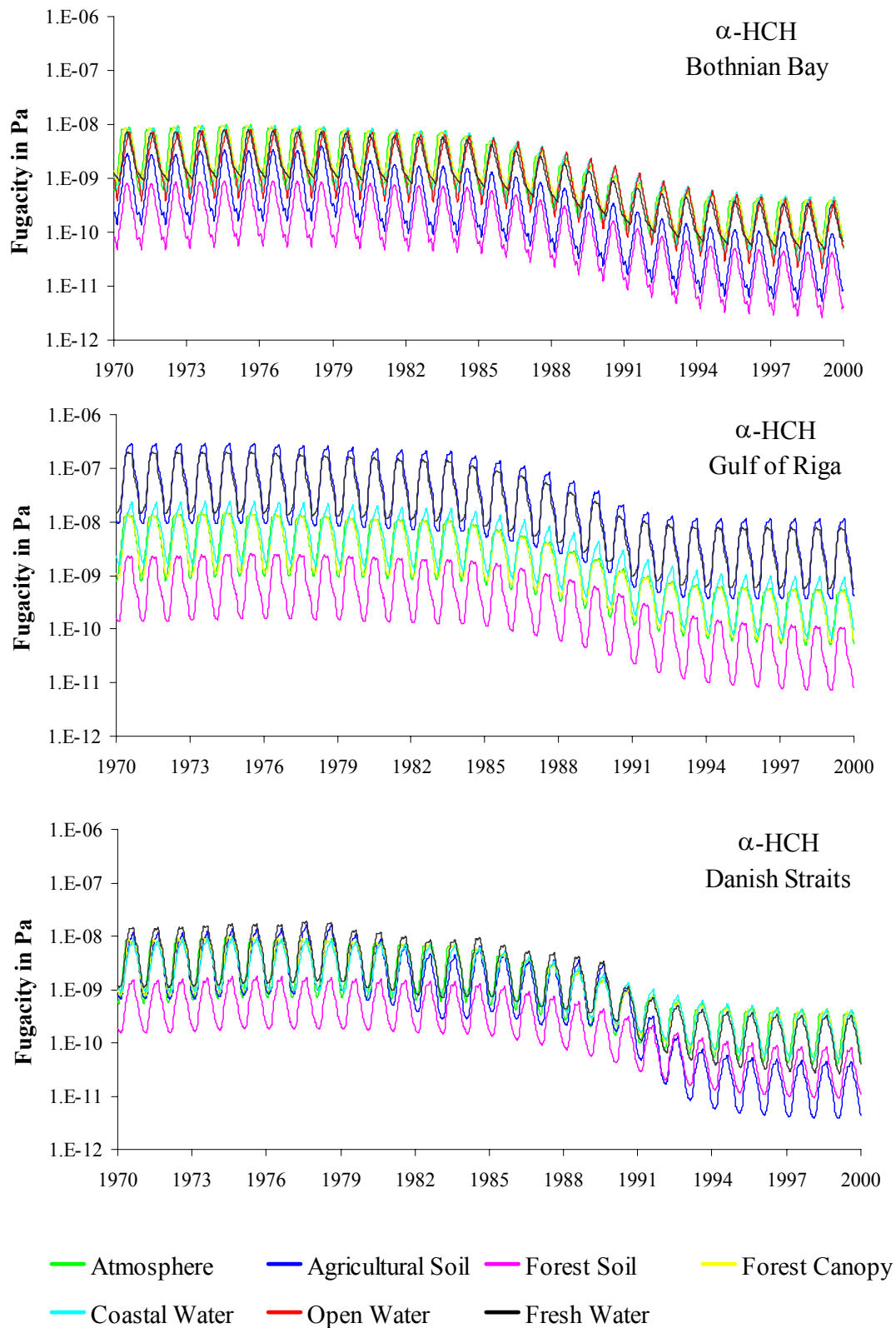

Figure 19: Fugacities of  $\gamma$ -HCH calculated for selected compartments of the POPCYCLING-Baltic model from 1970 to 2000.

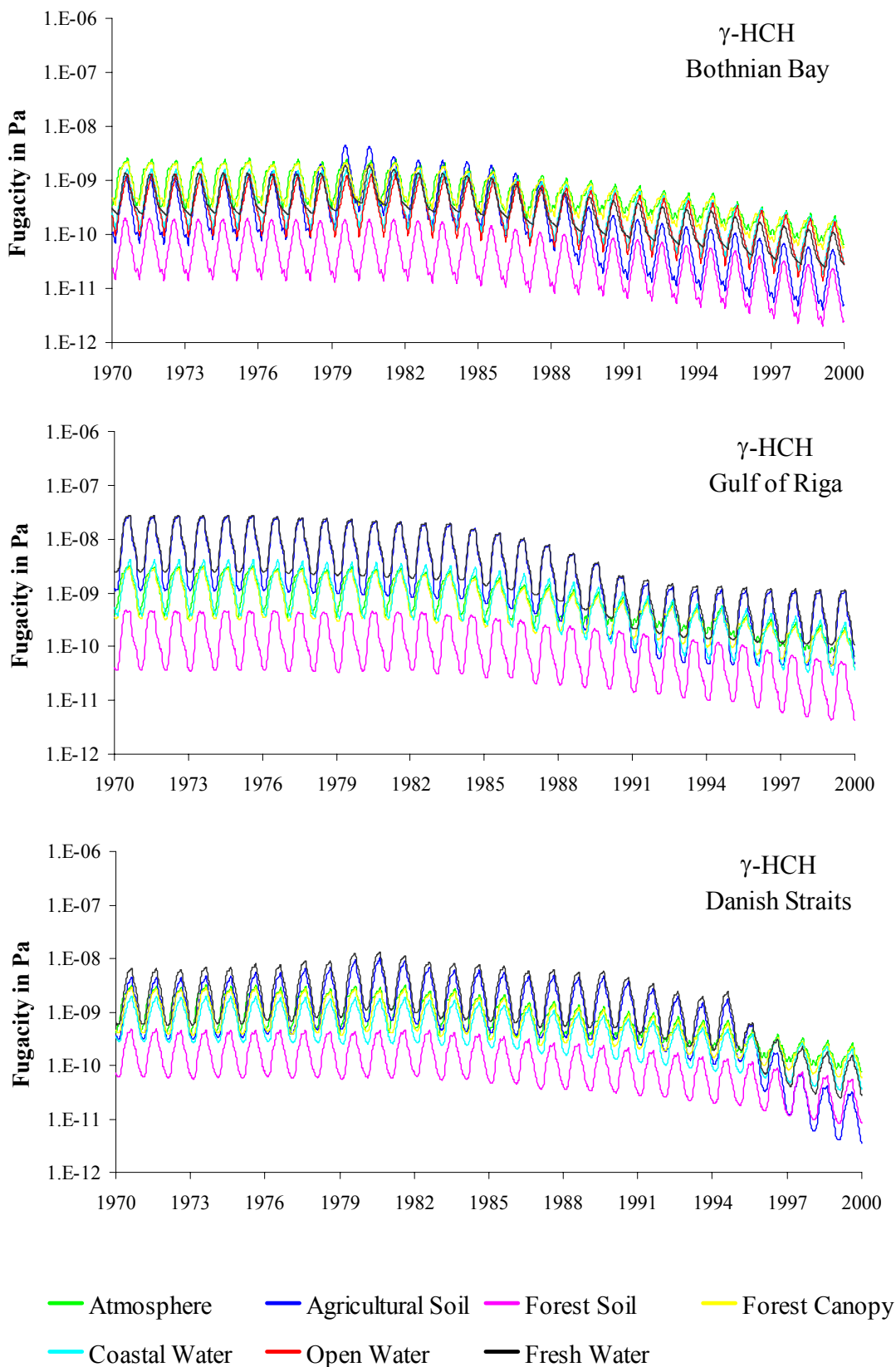

Figure 20: Fugacity fractions of  $\alpha$ -HCH between the atmosphere and various surface compartments calculated for selected compartments of the POPCYCLING-Baltic model from 1970 to 2000.

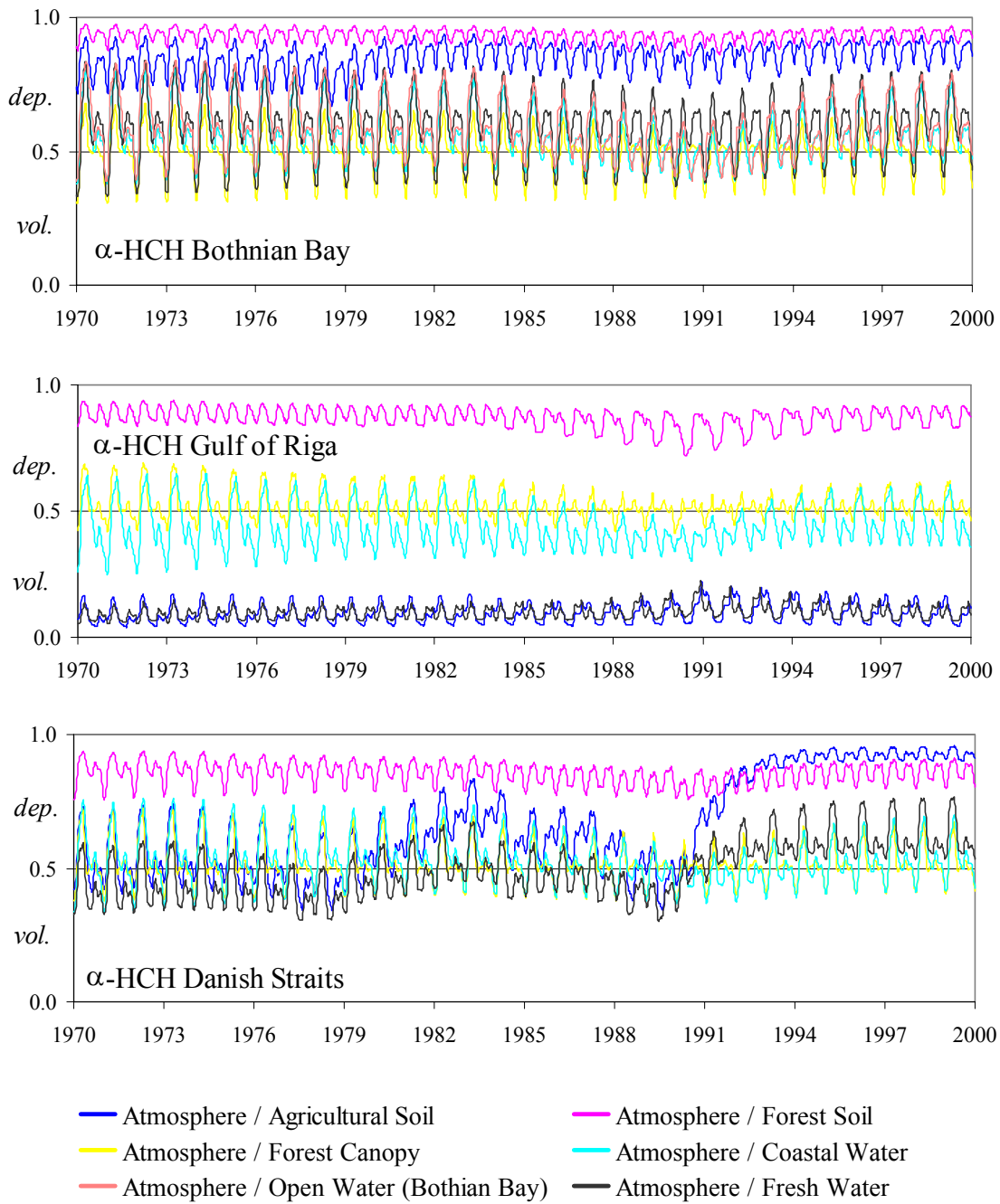



Figure 21: Fugacity fractions of  $\gamma$ -HCH between the atmosphere and various surface compartments calculated for selected compartments of the POPCYCLING-Baltic model from 1970 to 2000.

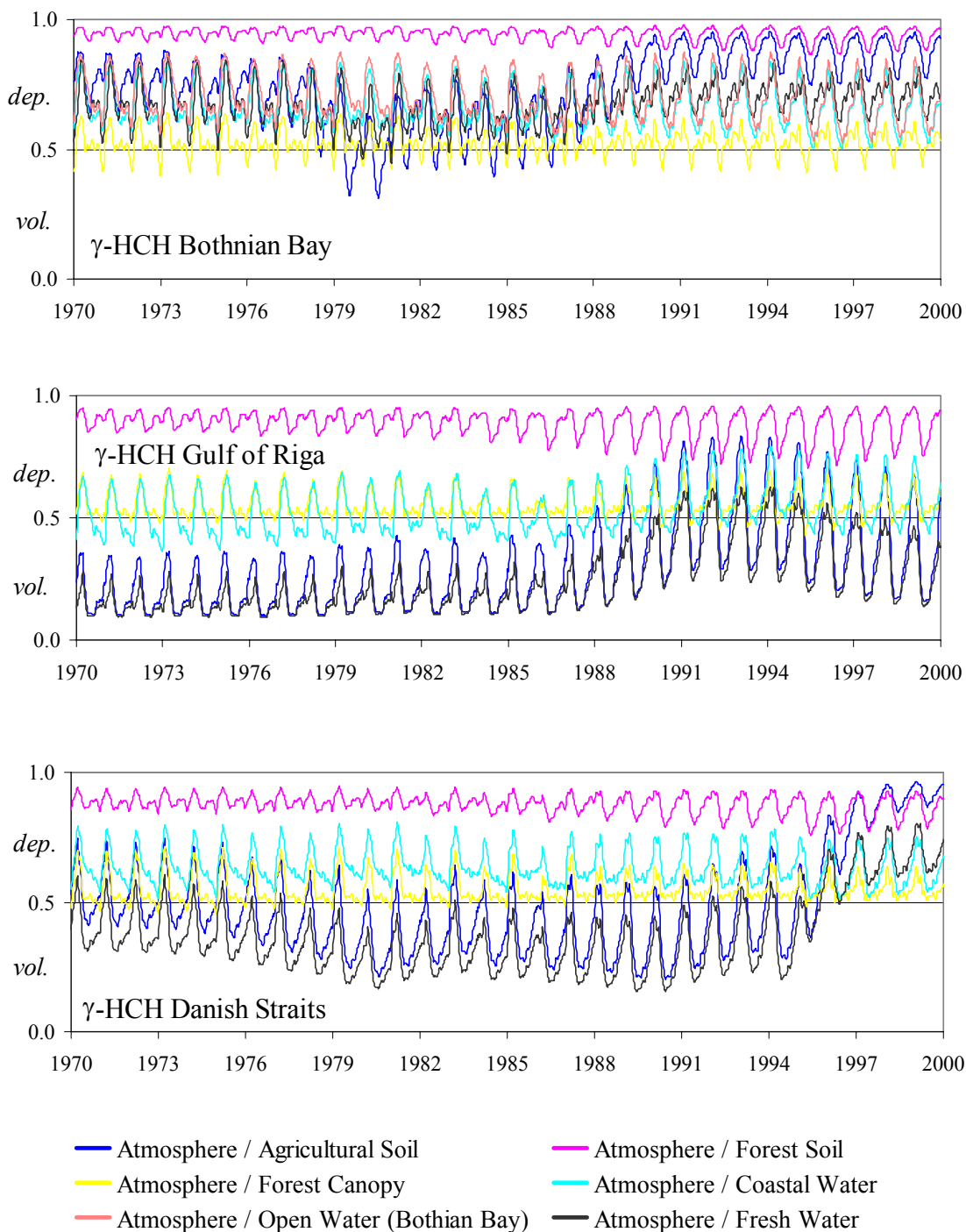

Figure 22: Fugacity fractions of  $\alpha$ -HCH between the water and sediment compartments calculated for selected compartments in various sub-regions of the POPCYCLING-Baltic model from 1970 to 2000.

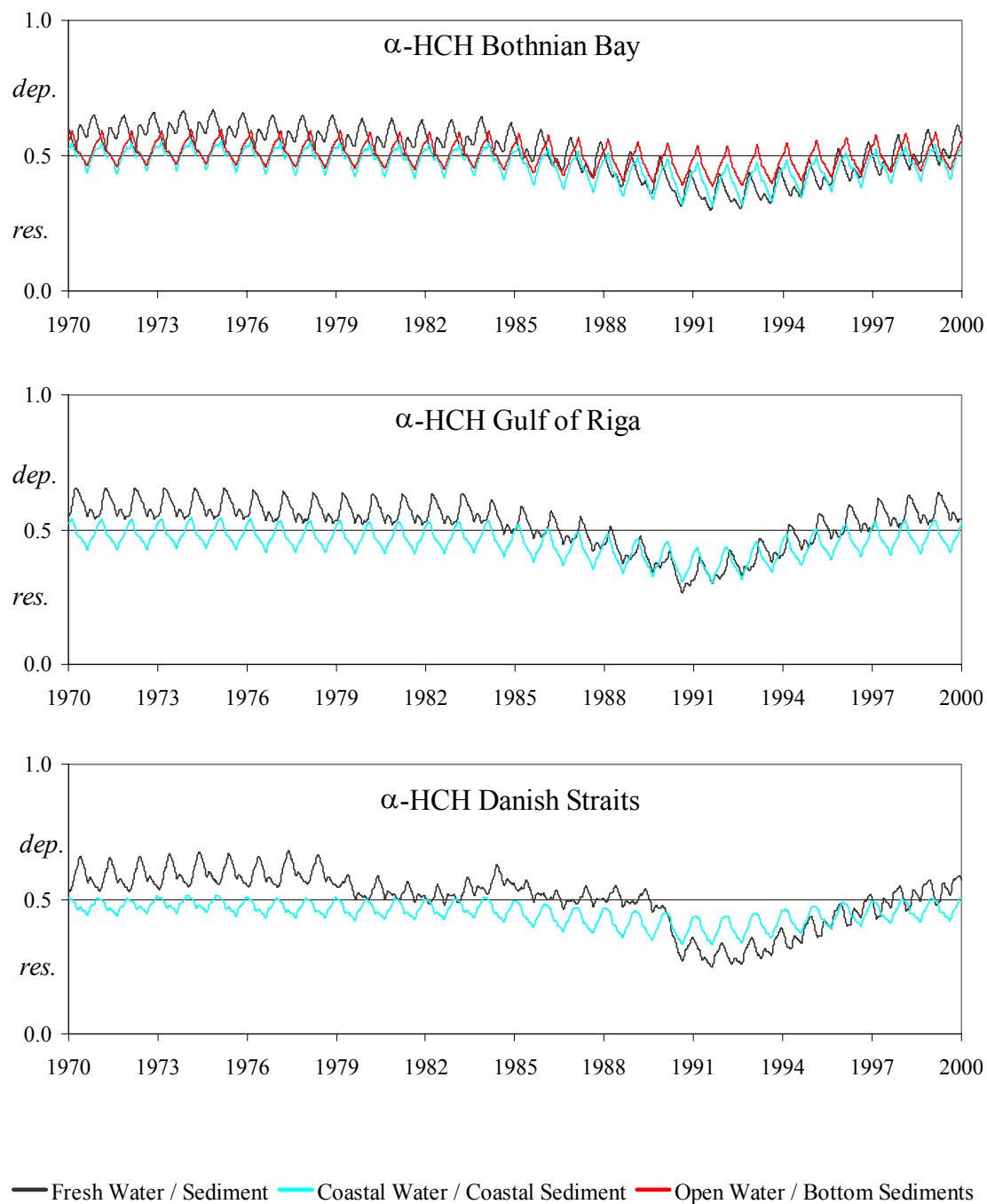
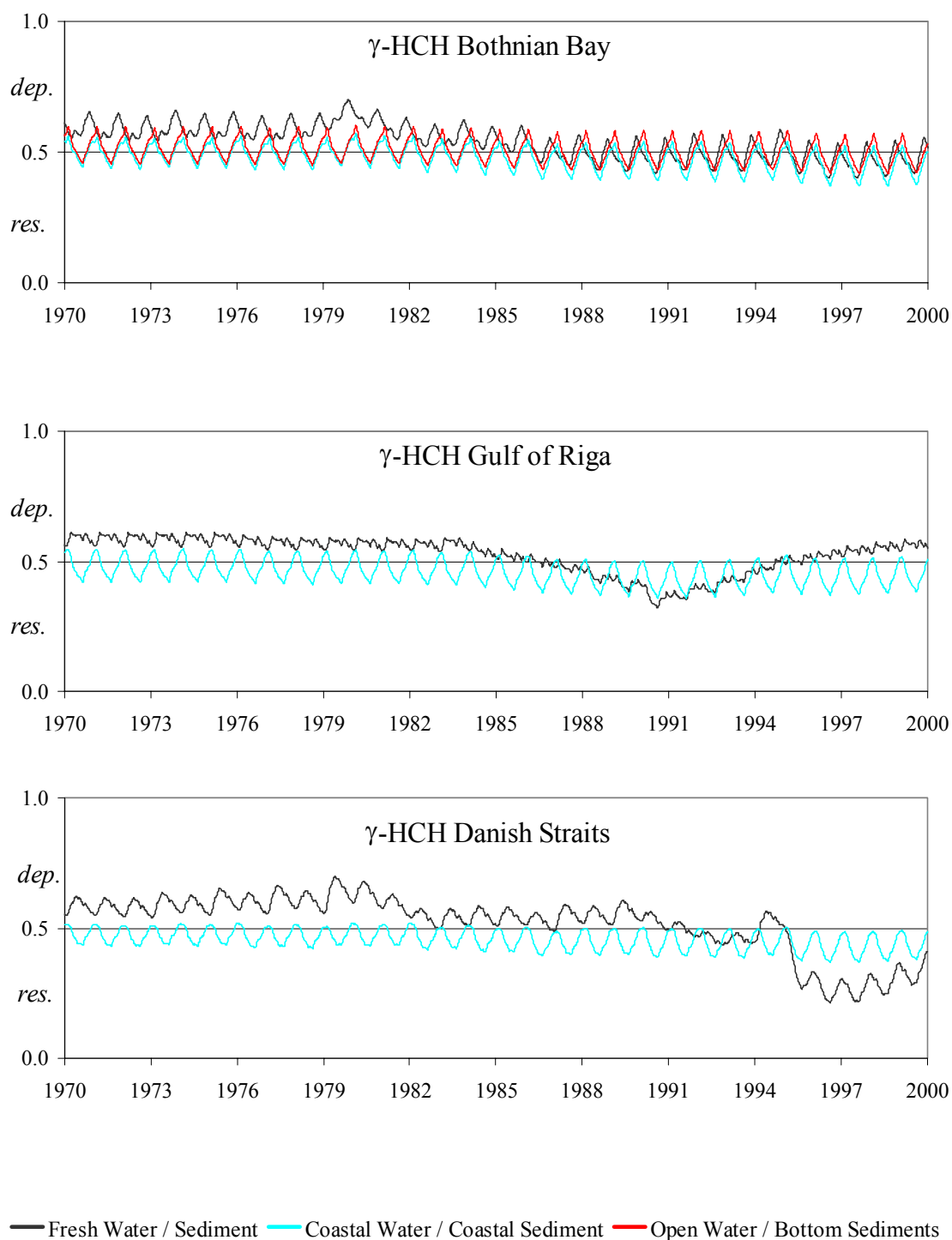

Figure 23: Fugacity fractions of  $\gamma$ -HCH between the water and sediment compartments calculated for selected compartments in various sub-regions of the POPCYCLING-Baltic model from 1970 to 2000.



## 6.8 Uniformity versus variability within the Baltic Sea environment

Measurements and the POPCYCLING-Baltic model both indicate a rather uniform distribution of HCHs throughout the Baltic Sea environment. During any year in the past thirty years, the annually averaged concentrations in atmosphere, seawater and foliage likely varied only by a factor of two to three within this large area. Only agricultural soils strongly reflect spatial differences in usage. Considering the large spatial differences in the usage of HCHs within this region, this uniformity in environmental distribution attests to the immense potential for the HCHs to be distributed widely in a short time.

The analysis presented here reveals that uniform concentrations do not imply uniform environmental behaviour in the various regions within the Baltic Sea environment. As has been shown, the relative importance of reservoirs and pathways differs widely between the regions, as do equilibrium status and the direction of air-surface exchange. In fact, the differences in behaviour between source regions and remote areas become understandable when interpreted in the context of the environment system as a whole striving towards a uniform distribution, or rather a distribution reflecting chemical equilibrium. Such a distribution is favoured, because it minimises the chemical potential within the overall system. The overall picture that emerges is that locally, i.e. within the areas where HCH pesticides have been applied, HCHs are being transferred from the soils of application to the water compartments and the forest system. On a regional scale HCHs are transported from source areas such as the Gulf of Riga to remote regions such as the Bothnian Bay and beyond, mostly by atmospheric currents and to a smaller extent also by seawater currents.

There are also differences in environmental behaviour of HCH between regions that are due to environmental characteristics, such as temperature, surface cover or the regional hydrological conditions. However, these are often more subtle and therefore easily obscured by the differences in emissions. An example is the special hydrodynamic conditions of the Gulf of Riga, where HCHs are being trapped in water that is relatively isolated from the rest of the Baltic Sea. Another example is the relatively important role of forests (*canopies and soils*) in the Bothnian Bay.

$\gamma$ -HCH reacts slightly faster with atmospheric OH radicals and is somewhat more soluble in water than  $\alpha$ -HCH. However, these differences are small and the differences in the modelled behaviour of the two isomers are generally due to the different emission history of the two isomers and not due to divergent chemical properties.

## 7. Discussion and recommendations

### 7.1 Discussion governing the specific model analysis presented

The model evaluation suggests that chemical input, both through direct emissions within the drainage basin and through advective inflow from adjacent areas, is the decisive factor controlling the spatial and temporal patterns of HCHs in the Baltic Sea environment. This should come as no surprise, as HCHs have an overall environmental persistence in the range of one year (Wania et al. 1999a), and as a result changes in the usage pattern in space and time are rapidly reflected in changes in chemical concentrations. Li (1999) also noted a direct relationship between the global  $\alpha$ -HCH usage trend and the time course of concentrations of  $\alpha$ -HCH in the Arctic atmosphere.

Deviations between predicted and measured HCH concentrations in a particular sub-region or during a particular time period can often only be rationalised by uncertain estimates of emissions and advective import. In fact, one of the benefits of a model evaluation exercise such as presented here is the ability to check whether the emission estimates are reasonable. For example, the evaluation of spatial patterns reveals that levels of  $\gamma$ -HCH in the Danish Straits were underpredicted in the early 1980s, suggesting that the usage of lindane in the SW part of the drainage basin may have been underestimated during that time period. Another example is the model-predicted decrease of  $\gamma$ -HCH concentration in air and seawater occurring earlier than is observed in the environment. This can only be reconciled assuming that the decrease of  $\gamma$ -HCH release experienced a similar delay, possibly as a result of the use of lindane stockpiles after restrictions were implemented.

The model result proved to be very sensitive to the boundary conditions, i.e., the assumptions concerning advective atmospheric inflow. The assumption of no HCH inflow is obviously unrealistic suggesting that sources within the drainage basin alone are not capable to explain the observed levels and significant transport into the region must occur. This was expected as HCHs are known to have substantial long range transport potential and to be distributed globally. The model performs reasonably well if it is assumed that concentrations in the inflowing media equal those in the media advected out of the model region. Best results are obtained when the boundary conditions are tuned based on available information on use intensity and air concentrations within and outside the model domain.

Despite the strong impact of chemical input strength, variable environmental conditions can significantly influence spatial distribution patterns. Notably, relatively high concentrations in the Northern reaches of the Baltic Sea environment, as observed in both sea water (Gaul, 1992) and pine needles (Jensen et al. 1992; Strachan et al. 1994), are reproduced by the model even though emissions are clearly much lower in the North. This can be attributed to the lower temperatures in these regions resulting in slower degradation and enhanced atmospheric deposition.

It should be obvious, that the presented simulation of the long term fate of HCHs in the Baltic Sea environment represents only a simple picture of reality and is subject to significant uncertainties. The emissions of HCHs within the drainage basin, and the import of HCH across the model boundary are uncertain. The environmental characteristics with an influence on chemical fate are much more variable in space and time than can be reflected in this fairly simple model. Also, the equations describing phase partitioning, transport and degradation are only approximate descriptions of reality. Finally, it is clear that many of the model results presented here are difficult or even impossible to validate. Nevertheless, we believe that a multimedia fate and transport model that has been evaluated by a thorough comparison of modelled and measured concentrations, can provide invaluable insight into the complex set of interactions that determine the overall fate of an environmental contaminant. Without such a tool it is extremely difficult to gain a comprehensive picture of chemical fate that accounts for the various pieces that are known from observational evidence. Sometimes, the model can even go beyond what is known from measurements and allow the deduction of information that hardly can be deduced from measurements. When appropriate, we have chosen to present the model results in relative rather than absolute terms. For example, we plot the relative distribution of the HCHs among various compartments rather than the absolute amounts, or we present the calculated fluxes and rates as fractions of the emission rate. Thus, much of the presented information remains valid, even if the emission estimates were to vary within the expected estimated uncertainty range (Breivik et al. 1999).

## **7.2 Prospects for modelling other chemicals using the POPCYCLING-Baltic model**

POPs form a diverse class of compounds to be inventoried with respect to their sources, congener/isomer composition and physical-chemical properties, influencing their fate in the environment. This was clearly recognised during the development of a European emission inventory for selected POPs during the project "Popcycling-Baltic" (Pacyna et al. 1999). Improved emission data for POPs have become of increasing importance as emission- or source driven fate models like the POPCYCLING-Baltic model are being developed. Many such models are focusing on temperature-dependent cycling processes between various media, and thus are using physical-chemical properties of isomers/congeners as input, due to the highly variable behaviour of individual compounds in the environment (Wania & Mackay, 1996). Thus, there seems to be a need to further strengthen the efforts on developing integrated inventories (*for the atmospheric, terrestrial and aquatic compartments*) with congener resolution. Since dynamic MFTMs, such as the POPCYCLING-Baltic also address current and future contamination levels, so there is also a need to obtain historical emission data, reflecting the potential lifetime of these pollutants in the environment. Emission inventories supplied by various research institutes (e.g. TNO, AEA, NILU) may serve as an important aid, e.g. for modelling activities by filling out temporal and spatial gaps in national reported data. However for the POPs, there is still an insufficient characterisation of sources as well as accompanying emission factors that result in high uncertainties of the estimates. As a matter of fact, the emission numbers for the HCHs as utilised here are considered as the most reliable emission data compiled through the POPCYCLING-project (Pacyna et al. 1999).

This in comparison to the intentionally produced POPs (e.g. PCBs) and unwanted by products of combustion (e.g. PAHs and PCDD/Fs). As the quality of model results depends heavily on the accuracy and completeness of emission data, further research on emissions of individual isomers and congeners of POPs should be in focus as much as modelling activities in order to obtain acceptable model estimates. At the same time, further use of the model for other POPs should be encouraged in spite of substantial uncertainties in current release estimates at the isomer / congener level, as the model may serve as a useful tool to pinpoint likely inconsistencies in emission inventories.

It should also be cautioned here that a satisfactory description of the fate of HCHs in the Baltic Sea environment does not imply that the model would describe the long term fate of other POPs equally well. For example, the uptake in forests and the transport with particulate organic carbon in the aqueous environment plays a minor role for the overall environmental fate of HCHs, yet these processes are very important for more hydrophobic organic substances. Further use and evaluation of the POPCYCLING-Baltic model for other contaminants, including substances less volatile, more persistent and more subject to association with particulate organic carbon than the HCHs, may improve our understanding of the overall environmental cycling of POPs under northern environmental conditions.

### **7.3 Application of the POPCYCLING-Baltic model in the EMEP program**

In 1999 a protocol on reduction of POPs in the N Economic Commission for Europe (ECE) region was signed within the UN ECE Convention on Long-range Transboundary Transport of Air Pollutants (LRTAP). As a follow-up of this event, POPs become a part of monitoring and modeling activities within the European Monitoring and Evaluation Programme (EMEP). One of the goals of the modeling activities within EMEP is to provide with information on source - receptor relationships for the pollutants within the UN ECE LRTAP Convention. Modeling of POP transport within air masses and their atmospheric deposition has been approached at the EMEP Meteorological Synthesizing Centre (MSC) - East in Moscow (e.g. MSC-E, 2000). The dispersion model at the MSC-East uses the information on POP releases in the UN ECE region and estimates the air concentrations and atmospheric deposition of POPs.

The POPCYCLING-Baltic model can be used as an extension of the EMEP POP model to simulate the fate and behavior of these pollutants in a terrestrial or aquatic ecosystem after POPs are deposited from the air to the terrestrial and aquatic surfaces. In this way the results of the EMEP POP model can be used as input data for the POPCYCLING-Baltic model, supported by the information on direct releases of POPs to terrestrial and aquatic ecosystems. Thus, the application of both models online can be very useful in studying the long-range transport of POPs from their emission regions to the receptor areas and the cycling of these pollutants through individual environmental media in these areas. In this way, the application of both models online can be used to address the question of what happen to POPs emitted in a given region, and where do they end.

Further development of the POPCYCLING-Baltic model application can be directed towards using the results of model estimates in a form of POP

concentration in various environmental media as input information for models simulating bioaccumulation of POPs in various organisms living in the marine and terrestrial ecosystems. Thus, the outcome of the abiotic POPCYCLING-Baltic model can be used as an input to biotic models, studying uptake and accumulation of POP by living organisms, and then the POP transfer through the food chain. This information may prove useful for other UN ECE LRTAP Convention units, discussing environmental effects of the Convention pollutants.

## 8. Acknowledgements

We acknowledge financial support from the UN ECE EMEP program.

We would like to thank all participants involved in POPCYCLING-Baltic project (ENV4-CT96-0214) for their valuable contributions to this study. In particular, we are indebted to Johan Persson, Dr. Eva Brorström-Lundén and Dr. Antonio Di Guardo. Furthermore, we acknowledge Dr. Jesper Christensen and Dr. David Henry for their contributions to the model parameterisation.

We further acknowledge Drs. Anders Bignert and Mats Olsson for the opportunity to use their fish concentration data.

## 9. References

- AMAP (1998) AMAP assessment report: Arctic pollution issues. Arctic Monitoring and Assessment Programme (AMAP). Oslo.
- Bartnicki, J., Barrett, K., Tsyro, S., Erdman, L., Gusev, A., Dutchak, S., Pekar, M., Lükewille, A. and Krognest, T. (1998) Atmospheric supply of nitrogen, lead, cadmium, mercury and lindane to the Baltic Sea. Oslo, EMEP/MSC-W Meteorological Synthesizing Centre – West. (Norwegian Meteorological Institute. Research Report No. 70).
- Bidleman, T.F., Wideqvist, U., Jansson, B. and Söderlund, R. (1987). Organochlorine pesticides and polychlorinated biphenyls in the atmosphere of Southern Sweden. *Atmos. Environ.*, 21, 641-654.
- Bidleman, T.F., Jantunen, L.M., Falconer, R.L., Barrie, L.A. and Fellin, P. (1995). Decline of hexachlorocyclohexane in the arctic atmosphere and reversal of air-sea exchange. *Geophys. Res. Lett.*, 22, 219-222.
- Bignert, A., Olsson, M., Persson, W., Jensen, S., Zakrisson, S., Litzén, K., Eriksson, U., Häggberg, L. and Alsberg, T. (1998). Temporal trends of organochlorines in Northern Europe, 1967-1995. Relation to global fractionation, leakage from sediments and international measures. *Environ. Pollut.*, 99, 177-198.
- Bintein, S. and Devillers, J. (1996) Evaluating the environmental fate of lindane in France. *Chemosphere*, 32, 2427-2440.



- Boehncke, A., Siebers, J. and Nolting, H.G. (1990) Investigations of selected pesticides from natural and model surfaces. *Chemosphere*, 21, 1109-1124.
- Breivik, K., Pacyna, J.M. and Münch, J. (1999). Use of  $\alpha$ -,  $\beta$ - and  $\gamma$ -hexachlorocyclohexane in Europe, 1970-1996. *Sci. Total Environ.*, 239, 151-163.
- Brorström-Lundén, E. (1995) Measurements of semivolatile organic compounds in air and deposition. Ph.D Thesis. Chalmers University of Technology / University of Göteborg.
- Brorström-Lundén, E. (1996) Atmospheric deposition of persistent organic compounds to the sea surface. *J. Sea Res.*, 35, 81-90.
- Brubaker, W.W. and Hites, R.A. (1998) OH reaction kinetics of gas-phase  $\alpha$ - and  $\gamma$ -hexachlorocyclohexane and hexachlorobenzene. *Environ. Sci. Technol.*, 32, 766-769.
- BSH (1991) Überwachung des Meeres. Bericht für das Jahr 1989. Teil II: Daten. Hamburg, Bundesamt für Seeschifffahrt und Hydrographie.
- Calamari, D., Tremolada, P., Di Guardo, A. and Vighi, M. (1994) Chlorinated hydrocarbons in pine needles in Europe: Fingerprint for the past and recent use. *Environ. Sci. Technol.*, 28, 429-434.
- CIEL (1998) Centre international d'études du Lindane. Letter from J.W.G Randall to Jörg Münch, dated 17.04.98.
- Cliath, M.M. and Spencer, W.F. (1972) Dissipation of pesticides from soil by volatilization of degradation products. *Environ. Sci. Technol.*, 6, 910-914.
- Dannenberger D. and Lertz, A. (1996) Polychlorinated biphenyls (PCB) and organochlorine pesticides in sediments of the Baltic and coastal waters of Mecklenburg-Vorpommern. *Deutsche Hydrogr. Z.*, 48, 5-26.
- Eriksson, G., Jensen, S., Kylin, H. and Strachan, W. (1989) The pine needle as a monitor of atmospheric pollution. *Nature*, 341, 42-44.
- Gaul, H. (1992) Temporal and spatial trends of organic micropollutants in the sea water of the Baltic Sea, the North Sea and the Northeast Atlantic. *ICES Marine Scientific Symposium*, 195, 110-126.
- Haque, A. and Schuphan, I. (1989) Feld – Freilandlysimeter – Vegetationskammer: Vergleichende Untersuchungen mit Lindan nach Sprühapplikation auf Kartoffelpflanzen (in German). *Z. Pflanzenkr. Pflanzenschutz*, 96, 173-186.
- Haugen, J.-E., Wania, F., Ritter, N. and Schlabach, M. (1998) Hexachlorocyclohexanes in air in Southern Norway. Temporal variation,

source allocation, and temperature dependence. *Environ. Sci. Technol.*, 32, 217-224.

HELCOM (1986) Water Balance of the Baltic Sea. A regional Cooperation project of the Baltic Sea States. International Summary Report. Helsinki (Baltic Sea Environmental Proceedings, 16).

Jensen, S., Johnels, A.G., Olsson, M. and Otterlind, G. (1969) DDT and PCB in Marine Animals from Swedish Waters. *Nature*, 224, 247-250.

Jensen, S., Eriksson, G. and Kylin, H. (1992) Atmospheric pollution by persistent organic compounds: Monitoring with pine needles. *Chemosphere*, 24, 229-245.

Jansson, B.-O. and Dahlberg, K., (1999) The Environmental status of the Baltic Sea in the 1940s, Today, and in the Future. *Ambio*, 28, 312-319.

Kutz, F.W., Wood, P.H. and Bottimore, D.P. (1991) Organochlorine pesticides and polychlorinated biphenyls in human adipose tissue. *Rev. environ. contam. toxicol.*, 120, 1-82.

Li, Y.-F., Bidleman, T.F., Barrie, L.A. and McConnell, L.L. (1998) Global hexachlorocyclohexane use trends and their impact on the arctic atmospheric environment. *Geophys. Res. Lett.*, 25, 39-41.

Li, Y.-F. (1999) Global technical hexachlorocyclohexane usage and its contamination consequences in the environment: From 1948 to 1997. *Sci. Total Environ.*, 232, 121-158.

Mackay, D. (1979) Finding fugacity feasible. *Environ. Sci. Technol.*, 13, 1218-1223.

Mackay, D. (1991) Multimedia environmental models. The fugacity approach. Boca Raton, Lewis Publishers.

Mackay, D., Shiu, W.-Y. and Ma, K.-C. (1999) Physical-chemical properties and environmental fate handbook. Chapman and Hall / CRCnetBASE 1999. CD-rom.

MSC-E (2000) Modelling long-range transport and deposition of POPs in the European region with emphasis to sea currents. The UN ECE European Monitoring and Evaluation Programme. Moscow (EMEP/MS-CHEM Technical Note 5/2000).

Oehme, M. and Manø, S. (1984) The long-range transport of organic pollutants to the Arctic. *Fres. Z. Anal. Chem.*, 319, 141-146.

- Pacyna, J.M. et al. (1999) Final report for Project POPCYCLING-Baltic. EU DGXII, Environment and Climate Program ENV4-CT96-0214. Available on CD-rom including technical report, the emission and environmental databases as well as the POPCYCLING-Baltic model. NILU, P.O. Box 100, N-2027 Kjeller, Norway.
- Persson, C. and Ullerstig, A. (1996) Model calculations of dispersion of lindane over Europe. (SMHI RMK, No. 68).
- Rodriguez, J.M., Ko, M.K.W., Sze, N.D. and Heisey, C.W. (1992) Impact of biomass burning on tropospheric CO and OH: A two-dimensional study. In: *Global biomass burning: Atmospheric, climatic and biological implications*. Ed. by J.S. Levine. Cambridge MA, The MIT Press, pp. 351-359.
- Rüdel, H. (1997) Volatilisation of pesticides from soil and plant surfaces. *Chemosphere*, 35, 143-152.
- Samuel, T. and Pillai, M.K.K. (1990) Effect of temperature and sunlight exposure on the fate of soil-applied [<sup>14</sup>C]-gamma-hexachlorocyclohexane. *Arch. Environ. Contam. Toxicol.*, 19, 214-220.
- Shatalov, V., Malanichev, A., Berg, T. and Larsen, R. (2000) Investigation and assessment of POP transboundary transport and accumulation in different media. Part I. Moscow, Meteorological Synthesizing Centre – East. (EMEP Report 4/2000).
- Shatalov, V. and Malanichev, A. (2000) Investigation and assessment of POP transboundary transport and accumulation in different media. Part II. Moscow. Meteorological Synthesizing Centre – East. (EMEP Report 4/2000).
- Strachan W.M.J., Eriksson, G., Kylin, H. and Jensen, S. (1994) Organochlorine compounds in pine needles: Methods and trends. *Environ. Toxicol. Chem.*, 13, 443-451.
- UN (1987) Environment statistics in Europe and North America. An experimental compendium. Part two: Statistical monograph of the Baltic Sea environment. New York, United Nations. (Statistical standards and studies, no. 39).
- UNEP (1995) Towards global action. International experts meeting on persistent organic pollutants. Vancouver, Canada, June 4-8, 1995. Meeting background Report.
- Van Jaarsveld, J.A., van Pul, W.A.L., de Leeuw, F.A.A.M. (1997) Modelling transport and deposition of persistent organic pollutants in the European region. *Atmos. Environ.*, 37, 1011-1024.
- Waliszewski, S.M. (1993) Residues of lindane, HCH isomers and HCB in the soil after lindane application. *Environ. Pollut.*, 82, 289-293.

- Wania, F. and Mackay, D. (1996) Tracking the distribution of persistent organic pollutants. *Environ. Sci. Technol.*, *30*, 390A-396A.
- Wania, F. (1999a) Differences, similarities, and complementarity of various approaches to modelling persistent organic pollutant distribution in the environment. Background paper presented at the WMO/EMEP/UNEP-workshop on modelling of atmospheric transport and deposition of persistent organic pollutants and heavy metals, WMO-Geneva, Switzerland, November 16-19, 1999. (Global Atmosphere Watch report, No. 136).
- Wania, F. (1999b) On the origin of elevated levels of persistent chemicals in the environment. *Environ. Sci. Pollut. Res.*, *6*, 11-19.
- Wania, F. and Mackay, D. (1999) The evolution of mass balance models of persistent organic pollutant fate in the environment. *Environ. Pollut.*, *100*, 223-240.
- Wania, F. and Mackay, D. (1999b) Global chemical fate of  $\alpha$ -hexachlorocyclohexane. Part 2. Use of a global distribution model for mass balancing, source apportionment, and trend prediction. *Environ. Toxicol. Chem.*, *18*, 1400-1407.
- Wania, F., Mackay, D., Li, Y.-F., Bidleman, T.F. and Strand, A. (1999a) Global chemical fate of  $\alpha$ -hexachlorocyclohexane. Part 1. Evaluation of a global distribution model. *Environ. Toxicol. Chem.*, *18*, 1390-1399.
- Wania, F., Persson, J., Di Guardo, A. and McLachlan, M.S. (2000) The POPCYCLING-Baltic Model. A non-steady state multicompartiment mass balance model of the fate of persistent organic pollutants in the Baltic Sea environment. Kjeller, Norwegian Institute for Air Research (NILU OR 10/2000). This report and the applied version of the POPCYCLING-Baltic model is also available through internet free of charge at the address: [www.scar.utoronto.ca/~wania/](http://www.scar.utoronto.ca/~wania/).
- Wania, F. and McLachlan, M.S. (2001) Estimating the influence of forests on the overall fate of semivolatile organic compounds using a multimedia fate model. *Environ. Sci. Technol.*, *35*, 582-590.
- Wania, F., Broman, D., Axelman, J., Näf, C. and Agrell, C. (2001) A multi-compartmental, multi-basin fugacity model describing the fate of PCBs in the Baltic Sea. In: *A systems analysis of the changing Baltic Sea*. Ed. by Wulff, F.; Larsson, P.; Rahm, L. Springer-Verlag, in press.
- Waymann, B. and Rüdell, H. (1995) Influence of air velocity, application dose, and test area size on the volatilisation of lindane. *Int. J. Environ. Anal. Chem.*, *58*, 371-378.

Willett, K.L., Ulrich, E.M. and Hites, R.A. (1998) Differential toxicity and environmental fates of hexachlorocyclohexane isomers. *Environ. Sci. Technol.*, 32, 2197-2207.

## 10. Abbreviations

- BHC - Abbreviation for BenzeneHexaChloride, used in the “old” literature for HCH
- HCH - Hexachlorocyclohexane (Figure 1, page 6)
- NILU – Norwegian Institute for Air Research
- MFTM - Multimedia Fate and Transport Model
- POP – Persistent Organic Pollutants